

# ■ Operating and installation instructions

**REMKO RVT-ARCTIC series**

**ARCTIC heat pumps**

RVT 264 ARCTIC, RVT 354 ARCTIC, RVT 524 ARCTIC, RVT 684 ARCTIC





**Read these operating instructions carefully before commissioning / using this device!**

**These instructions are an integral part of the system and must always be kept near or on the device.**

Subject to modifications; No liability accepted for errors or misprints!

**Translation of the original**

## Table of contents

<b>1</b>	<b>Safety and usage instructions</b>	<b>5</b>
1.1	General safety notes	5
1.2	Identification of notes	5
1.3	Personnel qualifications	5
1.4	Dangers of failure to observe the safety notes	6
1.5	Safety-conscious working	6
1.6	Safety instructions for the operator	6
1.7	Safety notes for installation, maintenance and inspection	6
1.8	Unauthorised modification and changes	7
1.9	Intended use	7
1.10	Warranty	7
1.11	Transport and packaging	7
1.12	Environmental protection and recycling	8
<b>2</b>	<b>Technical data</b>	<b>9</b>
2.1	Unit data	9
2.2	Unit dimensions	12
2.3	Distance-dependent sound level	13
2.4	Performance curves for heating and cooling	14
<b>3</b>	<b>Design and function</b>	<b>18</b>
3.1	Characteristics of REMKO inverter air conditioner with split design	18
3.2	Unit description	20
<b>4</b>	<b>Operation</b>	<b>21</b>
4.1	General notes	21
4.2	Display on indoor unit	21
4.3	Keys on the remote control	22
<b>5</b>	<b>Installation instructions for qualified personnel</b>	<b>29</b>
5.1	Important notes prior to installation	29
5.2	Wall openings	29
5.3	Installation materials	29
5.4	Layout, indoor unit	29
5.5	Installation, mounting outdoor unit	30
5.6	Minimum clearances	32
5.7	Oil return measures	33
5.8	Connection variants for the indoor unit	33
5.9	Connection of the indoor unit when the refrigerant piping is installed under the plaster	34
5.10	Wall bracket for the indoor units	35
<b>6</b>	<b>Installation</b>	<b>35</b>
6.1	Installation of the indoor unit	35
6.2	Connecting the refrigerant piping	36
6.3	Additional notes on connecting the refrigerant piping	38
6.4	Leak testing	38
6.5	Adding refrigerant	39
<b>7</b>	<b>Condensate drainage connection and safe drainage</b>	<b>39</b>
<b>8</b>	<b>Electrical wiring</b>	<b>41</b>
8.1	General Information	41
8.2	Connecting the indoor unit	41

# REMKO RVT-ARCTIC series

8.3	Connecting the outdoor unit.....	42
8.4	Electrical wiring diagram.....	43
8.5	Electrical drawings.....	45
8.6	Connection of a superordinate controller provided by the customer .....	48
<b>9</b>	<b>Before commissioning.....</b>	<b>51</b>
<b>10</b>	<b>Commissioning.....</b>	<b>51</b>
<b>11</b>	<b>Trouble-shooting, fault analysis and customer service.....</b>	<b>53</b>
11.1	Störungsbeseitigung und Kundendienst.....	53
11.2	Fehleranalyse Innengerät.....	55
<b>12</b>	<b>Care and maintenance.....</b>	<b>68</b>
<b>13</b>	<b>Shutdown.....</b>	<b>70</b>
<b>14</b>	<b>Exploded view and spare parts lists.....</b>	<b>71</b>
14.1	Exploded view - Indoor unit RVT 264-684 DC IT.....	71
14.2	Spare parts list - Indoor unit RVT 264-684 DC IT.....	72
14.3	Exploded view - Outdoor unit RVT 264-354 DC AT.....	73
14.4	Spare parts list - Outdoor unit RVT 264-354 DC AT.....	74
14.5	Exploded view - Outdoor unit RVT 524 DC AT.....	75
14.6	Spare parts list - Outdoor unit RVT 524 DC AT.....	76
14.7	Exploded view - Outdoor unit RVT 684 DC AT.....	77
14.8	Spare parts list - Outdoor unit RVT 684 DC AT.....	78
<b>15</b>	<b>Index.....</b>	<b>79</b>

# 1 Safety and usage instructions

## 1.1 General safety notes

Carefully read the operating manual before commissioning the units or their components for the first time. It provides useful tips and notes such as hazard warnings to prevent injury and material damage. Failure to follow the directions in this manual can endanger persons, the environment and the equipment itself or its components and will void any claims for liability.

Store this manual and the information required for the operation of this system (e.g. refrigerant data-sheet) in the vicinity of the unit.

The refrigerant used in the system is flammable. If applicable, observe the local safety conditions.



**Warning of inflammable substances!**

## 1.2 Identification of notes

This section provides an overview of all important safety aspects for proper protection of people and safe and fault-free operation. The instructions and safety notes contained within this manual must be observed in order to prevent accidents, personal injury and material damage.

Notes attached directly to the units must be observed in their entirety and be kept in a fully legible condition.

Safety notes in this manual are indicated by symbols. Safety notes are introduced with signal words which help to highlight the magnitude of the danger in question.

### **DANGER!**

Contact with live parts poses an immediate danger of death due to electric shock. Damage to the insulation or individual components may pose a danger of death.

### **DANGER!**

This combination of symbol and signal word warns of a situation in which there is immediate danger, which if not avoided may be fatal or cause serious injury.

### **WARNING!**

This combination of symbol and signal word warns of a potentially hazardous situation, which if not avoided may be fatal or cause serious injury.

### **CAUTION!**

This combination of symbol and signal word warns of a potentially hazardous situation, which if not avoided may cause injury or material and environmental damage.

### **NOTICE!**

This combination of symbol and signal word warns of a potentially hazardous situation, which if not avoided may cause material and environmental damage.



*This symbol highlights useful tips and recommendations as well as information for efficient and fault-free operation.*

## 1.3 Personnel qualifications

Personnel responsible for commissioning, operation, maintenance, inspection and installation must be able to demonstrate that they hold a qualification which proves their ability to undertake the work.

# REMKO RVT-ARCTIC series

## 1.4 Dangers of failure to observe the safety notes

Failure to observe the safety notes may pose a risk to people, the environment and the units. Failure to observe the safety notes may void any claims for damages.

In particular, failure to observe the safety notes may pose the following risks:

- The failure of important unit functions.
- The failure of prescribed methods of maintenance and repair.
- Danger to people on account of electrical and mechanical effects.

## 1.5 Safety-conscious working

The safety notes contained in this manual, the existing national regulations concerning accident prevention as well as any internal company working, operating and safety regulations must be observed.

## 1.6 Safety instructions for the operator

The operational safety of the units and components is only assured providing they are used as intended and in a fully assembled state.

- The units and components may only be set up, installed and maintained by qualified personnel.
- Protective covers (grills) over moving parts must not be removed from units that are in operation.
- Do not operate units or components with obvious defects or signs of damage.
- Contact with equipment parts or components can lead to burns or injury.
- The units and components must not be exposed to any mechanical load, extreme levels of humidity or extreme temperatures.
- Rooms in which refrigerant may escape shall be adequately aerated and ventilated. Otherwise, a risk of suffocation or fire exists.
- Do not leave children unsupervised when close to the system.
- Commissioning must be performed by authorised specialists exclusively. Deficient commissioning may lead to water leaks, electric shocks or fire. Commissioning must take place as described in the user manual.
- Only instruct authorised specialist personnel to perform maintenance or servicing.
- The system is filled with a flammable refrigerant. Never thaw any frozen unit components independently!

- Do not operate any further devices that produce high heat or naked flames in the same room.
- All housing parts and unit openings, e.g. air inlets and outlets, must be kept clear.
- The units must be inspected by a service technician to ensure that they are safe to use and fully functional at least once yearly. Visual inspections and cleaning may be performed by the operator when the units are disconnected from the mains.

## 1.7 Safety notes for installation, maintenance and inspection

- The refrigerant R32 used in the system is flammable. If applicable, observe the local safety conditions.
- Keep the cooling circuit clear of other gases and foreign substances. Only fill the cooling circuit with the refrigerant R32.
- Only use the accessories, components and appropriately marked parts provided. The use of non-standardised components may result in water leaks, electric shocks and fire.
- Only install and store the units in rooms larger than 4 m<sup>2</sup>. With a failure to comply, leaks may result in the room filling with a flammable mixture!

The minimum room size of 4 m<sup>2</sup> required for installation and storage pertains to the basic fill quantity of the unit. This varies according to the installation type and total fill quantity of the system. The calculation must take place in accordance with valid DIN standards. Make sure that the installation site is suitable for safe unit operation.

- Only mount the unit components on structurally suitable brickwork.
- The units must not be installed in rooms in which further devices that produce heat are operated (heaters, open hearths).
- Make sure the installation room is sufficiently ventilated.
- Interventions in the cooling circuit are only possible after completely draining the refrigerant. Never solder or grind unit components!
- Note that refrigerant may be odourless.
- Never operate the air conditioning unit in a humid room, such as a bathroom or laundry room. If the humidity is too high, this can cause short circuits on electrical parts.
- The product must be correctly earthed at all times, otherwise it may induce electric shocks.
- Attach the condensate drain as described in the operating manual. The inadequate drainage of condensate can lead to water damage in your apartment.

- All persons who intervene in the cooling circuit must hold a valid certificate from the chamber of industry and commerce, which confirms their ability to work with refrigerant.
- Appropriate hazard prevention measures must be taken to prevent risks to people when performing installation, repair, maintenance or cleaning work on the units.
- The setup, connection and operation of the units and its components must be undertaken in accordance with the usage and operating conditions stipulated in this manual and comply with all applicable regional regulations.
- Regional regulations and laws as well as the Water Ecology Act must be observed.
- The power supply should be adapted to the requirements of the units.
- Units may only be mounted at the points provided for this purpose at the factory. The units may only be secured or mounted on stable structures, walls or floors.
- The units and components should not be operated in areas where there is a heightened risk of damage. Observe the minimum clearances.
- The units and components must be kept at an adequate distance from flammable, explosive, combustible, abrasive and dirty areas or atmospheres.
- Safety devices may not be modified or bypassed.
- The connection of the indoor unit must be established as a permanent connection; a detachable, reusable connection is not permissible.

## 1.8 Unauthorised modification and changes

Modifications or changes to units and components are not permitted and may cause malfunctions. Safety devices may not be modified or bypassed. Original replacement parts and accessories authorised by the manufacturer ensure safety. The use of other parts may invalidate liability for resulting consequences.

## 1.9 Intended use

Depending on the model, the units and the additional fittings with which they are equipped are only intended to be used as an air-conditioner for the purpose of cooling or heating the air in an enclosed space.

Any different or additional use is a non-intended use. The manufacturer/supplier assumes no liability for damages arising from a non-intended use. The user bears the sole risk in such cases. Intended use also includes working in accordance with the operating and installation instructions and complying with the maintenance requirements.

The threshold values specified in the technical data must not be exceeded.

## 1.10 Warranty

For warranty claims to be considered, it is essential that the ordering party or its representative complete and return the "certificate of warranty" to REMKO GmbH & Co. KG at the time when the units are purchased and commissioned.

The warranty conditions are detailed in the "General business and delivery conditions". Furthermore, only the parties to a contract can conclude special agreements beyond these conditions. In this case, contact your contractual partner in the first instance.

## 1.11 Transport and packaging

The devices are supplied in a sturdy shipping container. Please check the equipment immediately upon delivery and note any damage or missing parts on the delivery and inform the shipper and your contractual partner. For later complaints can not be guaranteed.

### **WARNING!**

**Plastic films and bags etc. are dangerous toys for children!**

Why:

- Leave packaging material are not around.
- Packaging material may not be accessible to children!

# REMKO RVT-ARCTIC series

## 1.12 Environmental protection and recycling

### Disposal of packaging

All products are packed for transport in environmentally friendly materials. Make a valuable contribution to reducing waste and sustaining raw materials. Only dispose of packaging at approved collection points.



### Disposal of equipment and components

Only recyclable materials are used in the manufacture of the devices and components. Help protect the environment by ensuring that the devices or components (for example batteries) are not disposed in household waste, but only in accordance with local regulations and in an environmentally safe manner, e.g. using certified firms and recycling specialists or at collection points.





## 2 Technical data

### 2.1 Unit data

Series		RVT 264 DC ARCTIC	RVT 354 DC ARCTIC	RVT 524 DC ARCTIC	RVT 684 DC ARCTIC
Operating mode		Inverter wall-mounted room air conditioner combination for cooling and heating			
Nominal heat capacity <sup>2)</sup>	kW	2.40 (0.80-3.90)	2.50 (0.90-5.10)	4.20 (1.30-7.00)	5.60 (2.10-9.40)
Energy efficiency ratio SCOP <sup>4)</sup>		4.0	4.0	4.0	4.0
Rated power consumption, electrical heating <sup>2)</sup>	kW	0.78	1.17	1.39	2.11
Rated elec. curr. consump., heating <sup>2)</sup>	A	3.40	5.10	6.00	9.20
Power consumpt., annual, Q <sub>HE</sub> <sup>3)</sup>	kWh	840	875	1470	1960
Energy efficiency ratio, heating <sup>2)</sup>		A+	A+	A+	A+
Nominal cooling output <sup>1)</sup>	kW	2.60 (1.20-3.40)	3.50 (1.40-4.60)	5.30 (2.00- 6.20)	7.30 (3.00-8.40)
Energy efficiency ratio SEER <sup>1)</sup>		6.8	6.5	7.1	6.9
Rated power consumption, electrical cooling <sup>1)</sup>	kW	0.77	1.25	1.50	2.26
Rated elec. curr. consump., cooling <sup>1)</sup>	A	3.30	5.40	6.50	9.80
Power consumpt., annual, Q <sub>CE</sub> <sup>3)</sup>	kWh	134	188	261	370
Energy efficiency ratio, cooling <sup>1)</sup>		A++	A++	A++	A++
Max. power consumption	kW	2.08	2.20	2.55	3.60
Max. current consumption	A	9.50	10.00	11.50	16.00
EDP no.		1623066	1623076	1623086	1623096





<sup>1)</sup> Air inlet temp. TK 27 °C / FK 19 °C, outside temperature TK 35 °C, FK 24 °C, max. air flow volume, 5 m pipe length

<sup>2)</sup> Air inlet temp. TK 20 °C, outside temperature TK 7 °C, FK 6 °C, max. air flow volume, 5m pipe length

<sup>3)</sup> The specified value is based on results from standard testing.  
The actual consumption depends on the use and location of the unit

<sup>4)</sup> The specified value is based on the average heating period

# REMKO RVT-ARCTIC series

Data specific to indoor unit		RVT 264 DC  ARCTIC	RVT 354 DC  ARCTIC	RVT 524 DC  ARCTIC	RVT 684 DC  ARCTIC
Application area (room volume), approx.	m <sup>3</sup>	80	110	160	230
Adjustment range room temp.	°C	+17 to +30 +8 with "FP" function			
Operating range	°C	+17 to +30			
Air flow volume per level	m <sup>3</sup> /h	329/433/486	360/490/550	550/720/810	650/970/1050
Sound pressure level per speed setting <sup>5)</sup>	dB (A)	29/34/41	30/37/41	33/41/45	35/44/46
Sound pressure level, Silent/Turbo mode <sup>5)</sup>	dB (A)	22/42	23/43	24/48	27/51
Sound power level max.	dB(A)	53	54	57	59
Enclosure class	IP	X 0			
Condensate drainage connection	mm	18			
Dimensions: H/W/D	mm	300/716/193	300/803/193	325/964/222	342/1106/323
Weight	kg	7.5	8.2	10.8	14.3
EDP no.		1623068	1623078	1623088	1623098

<sup>5)</sup> At distance of 1 m in the open air; specified values are maximum values

Data specific to outdoor unit		RVT 264 DC ARCTIC	RVT 354 DC ARCTIC	RVT 524 DC ARCTIC	RVT 684 DC ARCTIC
Power supply	V/Ph/Hz	230 / 1~ / 50			
Operating range, cooling	°C	+5 to +50 <sup>7)</sup>			
Operating range, heating	°C	-20 to +34			
Air flow rate, max.	m <sup>3</sup>	1900		2100	2,700
Enclosure class	IP	24			
Sound power level max.	dB (A)	58	60	60	65
Sound pressure level <sup>5)</sup>	dB (A)	55	55	57	59
Refrigerant <sup>6)</sup>		R32			
Refrigerant, basic capacity	kg	0.70	0.80	1.25	1.60
CO <sub>2</sub> equivalent	t	0.47	0.54	0.84	1.08
Max. operating pressure	kPa	4600 / 1700			
Refrigerant, addit. quantity >5m	g/m	20			40
Refrigerant piping, max. length	m	25	25	30	45
Refrigerant piping, max. height	m	10	10	15	20
Refrigerant connection Liquid line	Inches (mm)	1/4 (6.35)	1/4 (6.35)	1/4 (6.35)	3/8 (9.52)
Refrigerant connection Suction pipe	Inches (mm)	3/8 (9.52)	3/8 (9.52)	1/2 (12.70)	5/8 (15.90)
Dimensions: H/W/D	mm	555/770/300		554/800/333	702/845/363
Weight	kg	26.4	26.5	37.0	48.0
EDP no.		1623067	1623077	1623087	1623097

<sup>5)</sup> At distance of 1 m in the open air; specified values are maximum values

<sup>6)</sup> Contains greenhouse gas per the Kyoto protocol, GWP 675  
(for further information, see chapter "Adding refrigerant")

<sup>7)</sup> This can be extended to -15 °C with the appropriate accessory kit

# REMKO RVT-ARCTIC series

## 2.2 Unit dimensions

### Outdoor units

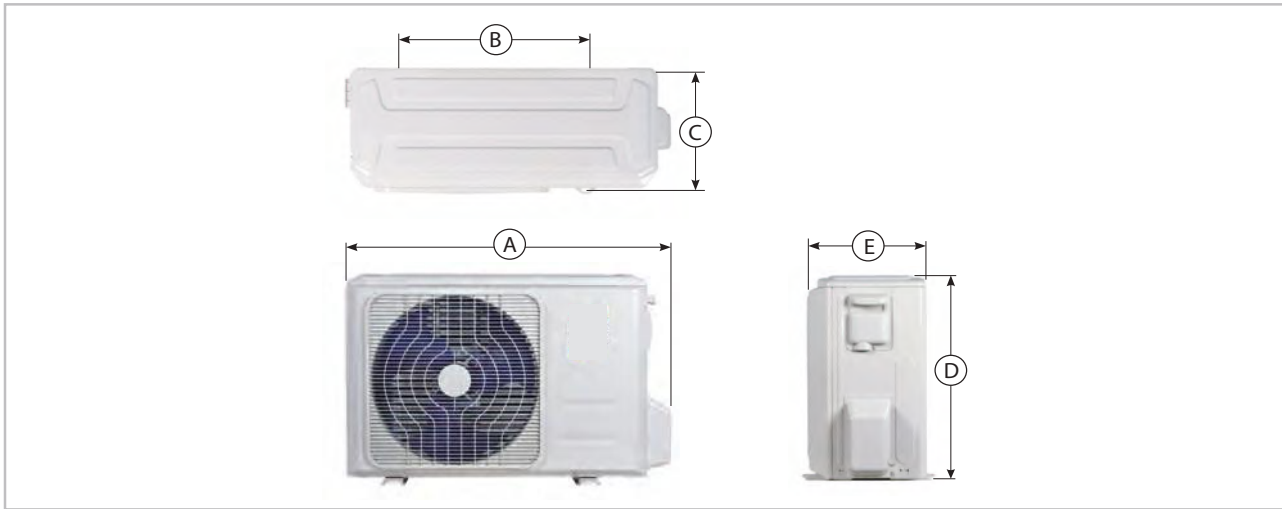

Dimensions (mm)	A	B	C	D	E
RVT 264-354 DC AT	770	487	298	555	300
RVT 524 DC AT	800	514	340	554	333
RVT 684 DC AT	845	540	350	702	363

### Indoor units

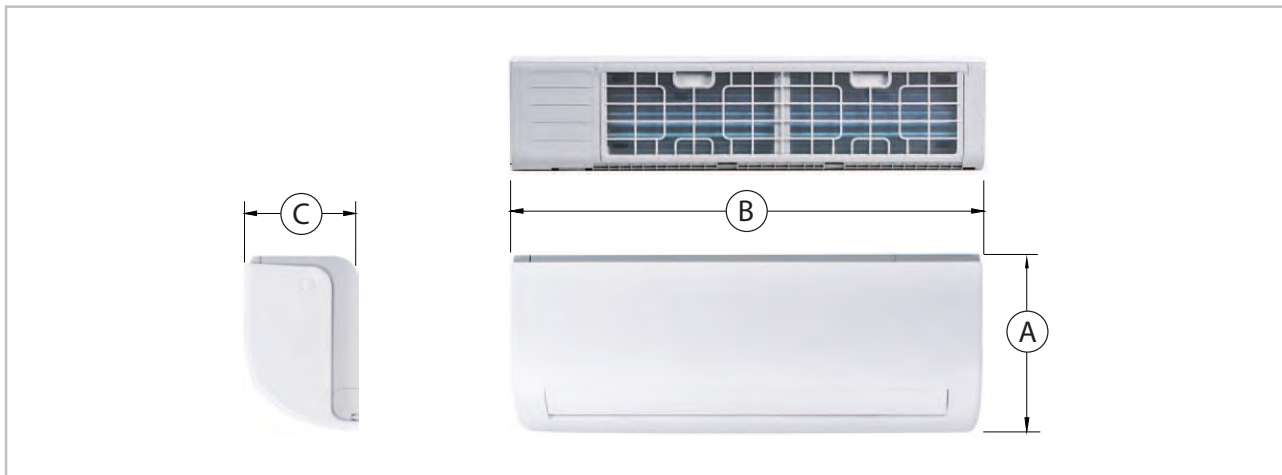

Dimensions (mm)	A	B	C
RVT 264 DC IT	300	716	193
RVT 354 DC IT	300	803	193
RVT 524 DC IT	325	964	222
RVT 684 DC IT	342	1106	232

## 2.3 Distance-dependent sound level

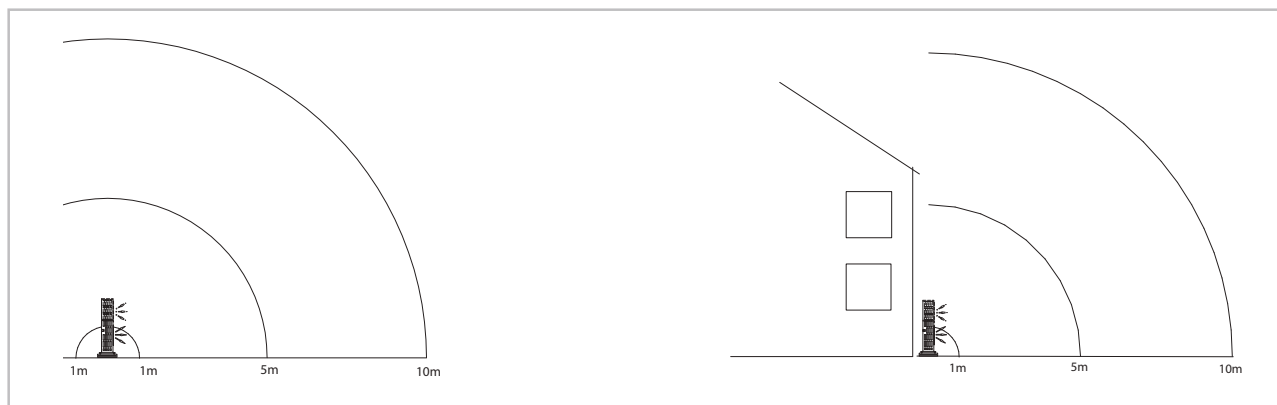

Fig. 1: Distance-dependent sound level for the outdoor unit in relation to installation type, in accordance with the drawing

Distance-dependent sound level *)						
Unit type	Max. sound power in [dB(A)]	Installation type, in accordance with the drawing	1m [dB(A)]	5m [dB(A)]	10m [dB(A)]	15m [dB(A)]
RVT 264 DC	58	In free field	50.0	36.0	28.0	26.5
RVT 354 DC	60	In free field	52.0	38.0	32.0	28.5
RVT 524 DC	60	In free field	52.0	38.0	32.0	28.5
RVT 684 DC	65	In free field	57.0	43.0	37.0	33.5

\*) All information provided without guarantee. Exact sound values must be determined by a sound expert!

# REMKO RVT-ARCTIC series

## 2.4 Performance curves for heating and cooling

### Heating capacity RVT 264 DC

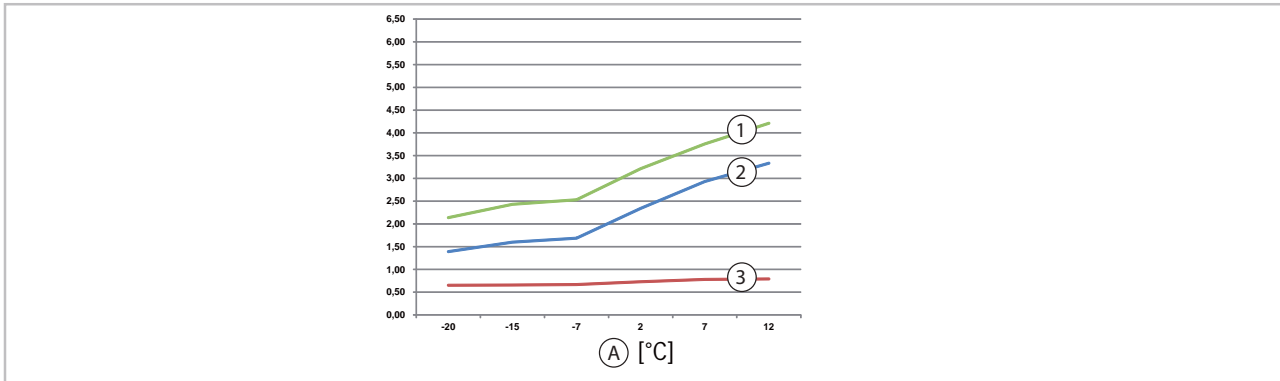

Fig. 2: Performance curves, heating RVT 264 DC (data for room temperature 20 °C)

- A: Outside temperature / 1: COP
- 2: Heating capacity in kW
- 3: Power consumption in kW

Outside temperature in °C	-20	-15	-7	2	7	12
Heating capacity in kW	1.39	1.60	1.69	2.34	2.93	3.33
Power consumption in kW	0.65	0.66	0.67	0.73	0.78	0.79
COP	2.14	2.43	2.53	3.21	3.76	4.21

### Cooling capacity RVT 264 DC

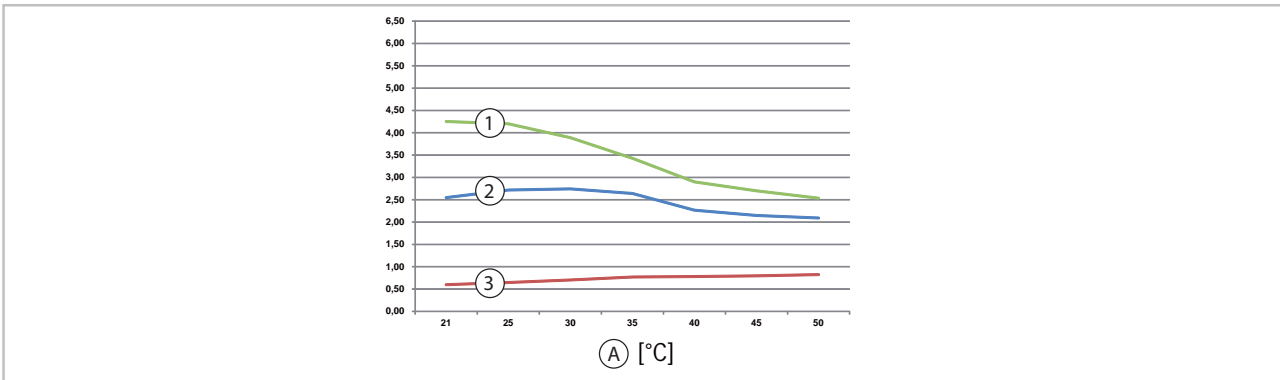

Fig. 3: Performance curves, cooling RVT 264 DC (data for room temperature FK27°/TK19 °C)

- A: Outside temperature / 1: EER
- 2: Cooling capacity in kW
- 3: Power consumption in kW

Outside temperature in °C	21	25	30	35	40	45	50
Cooling capacity in kW	2.55	2.72	2.74	2.64	2.27	2.15	2.09
Power consumption in kW	0.60	0.65	0.70	0.77	0.78	0.80	0.83
EER	4.25	4.20	3.89	3.43	2.90	2.70	2.54

### Heating capacity RVT 354 DC

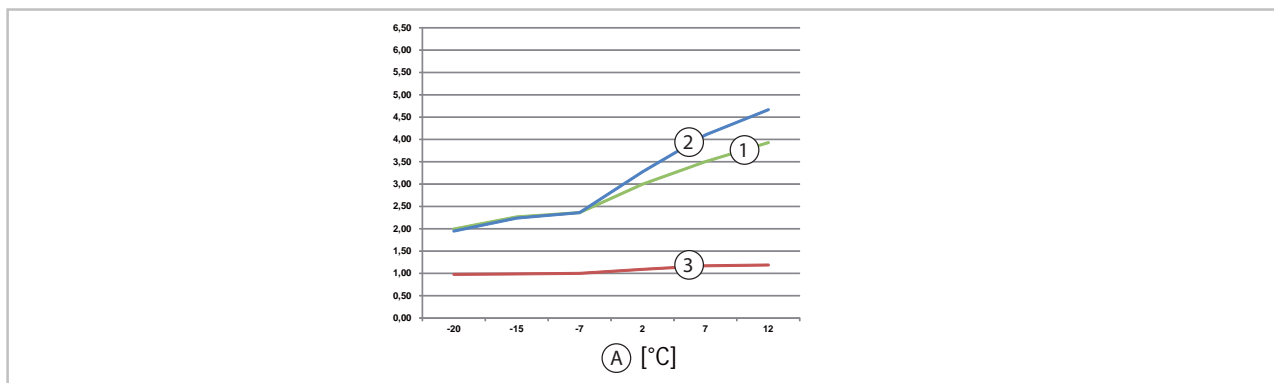

Fig. 4: Performance curves, heating RVT 354 DC (data for room temperature 20 °C)

- A: Outside temperature
- 1: COP
- 2: Heating capacity in kW
- 3: Power consumption in kW

Outside temperature in °C	-20	-15	-7	2	7	12
Heating capacity in kW	1.95	2.24	2.36	3.27	4.10	4.67
Power consumption in kW	0.98	0.99	1.00	1.09	1.17	1.19
COP	1.99	2.27	2.36	3.00	3.50	3.93

### Cooling capacity RVT 354 DC

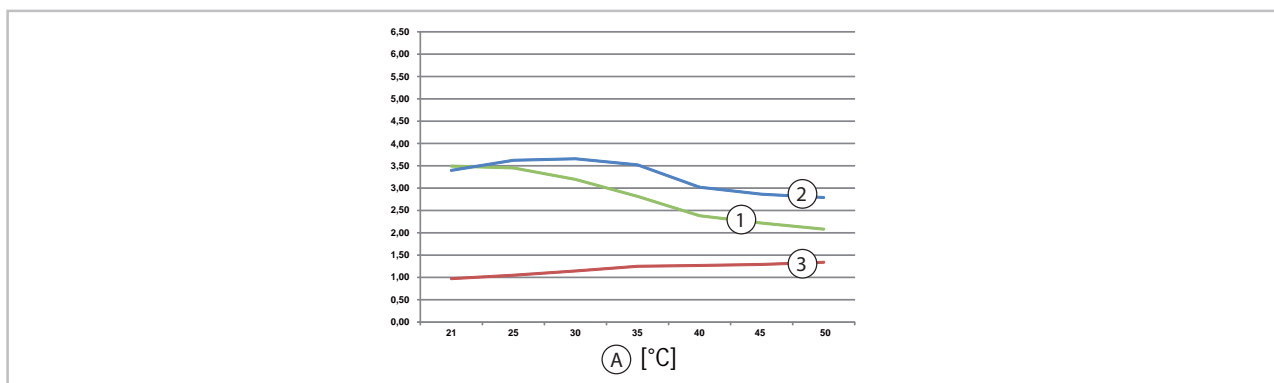

Fig. 5: Performance curves, cooling RVT 354 DC (data for room temperature FK27°/TK19 °C)

- A: Outside temperature
- 1: EER
- 2: Cooling capacity in kW
- 3: Power consumption in kW

Outside temperature in °C	21	25	30	35	40	45	50
Cooling capacity in kW	3.40	3.62	3.66	3.52	3.02	2.86	2.79
Power consumption in kW	0.97	1.05	1.14	1.25	1.27	1.29	1.34
EER	3.49	3.45	3.20	2.82	2.38	2.22	2.08

# REMKO RVT-ARCTIC series

## Heating capacity RVT 524 DC

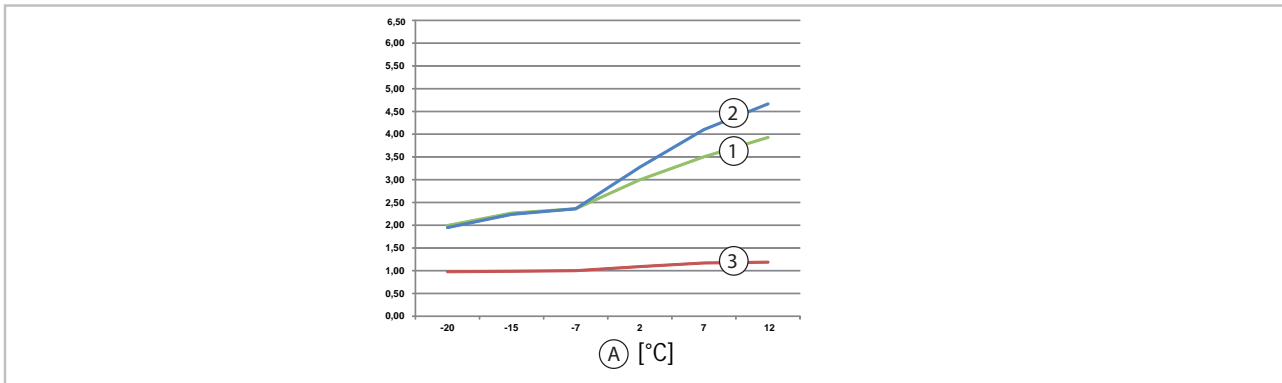

Fig. 6: Performance curves, heating RVT 524 DC (data for room temperature 20 °C)

- A: Outside temperature
- 1: COP
- 2: Heating capacity in kW
- 3: Power consumption in kW

Outside temperature in °C	-20	-15	-7	2	7	12
Heating capacity in kW	2.65	3.04	3.21	4.45	5.57	6.34
Power consumption in kW	1.16	1.17	1.19	1.30	1.39	1.41
COP	2.28	2.59	2.70	3.43	4.01	4.49

## Cooling capacity RVT 524 DC

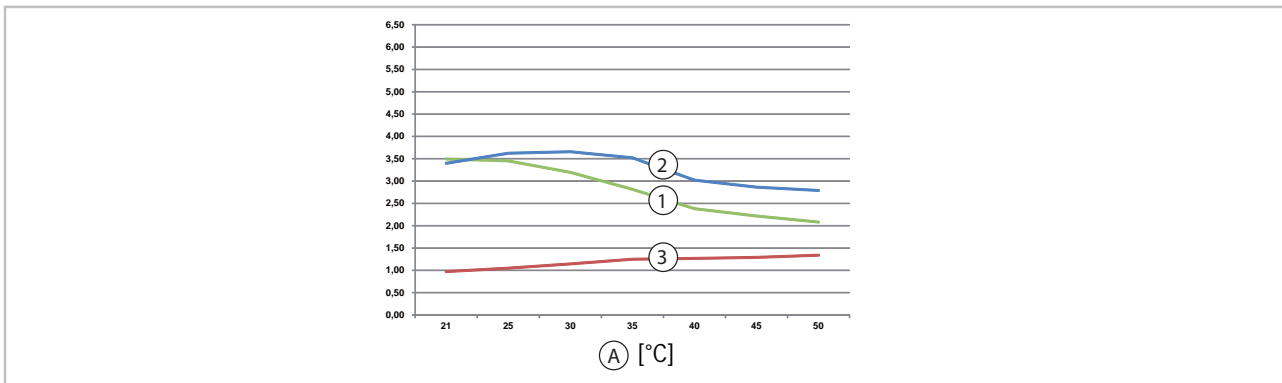

Fig. 7: Performance curves, cooling RVT 524 DC (data for room temperature FK27°/TK19 °C)

- A: Outside temperature
- 1: EER
- 2: Cooling capacity in kW
- 3: Power consumption in kW

Outside temperature in °C	21	25	30	35	40	45	50
Cooling capacity in kW	5.10	5.44	5.48	5.28	4.53	4.30	4.18
Power consumption in kW	1.17	1.26	1.37	1.50	1.52	1.55	1.61
EER	4.37	4.31	4.00	3.52	2.98	2.77	2.60



### Heating capacity RVT 684 DC

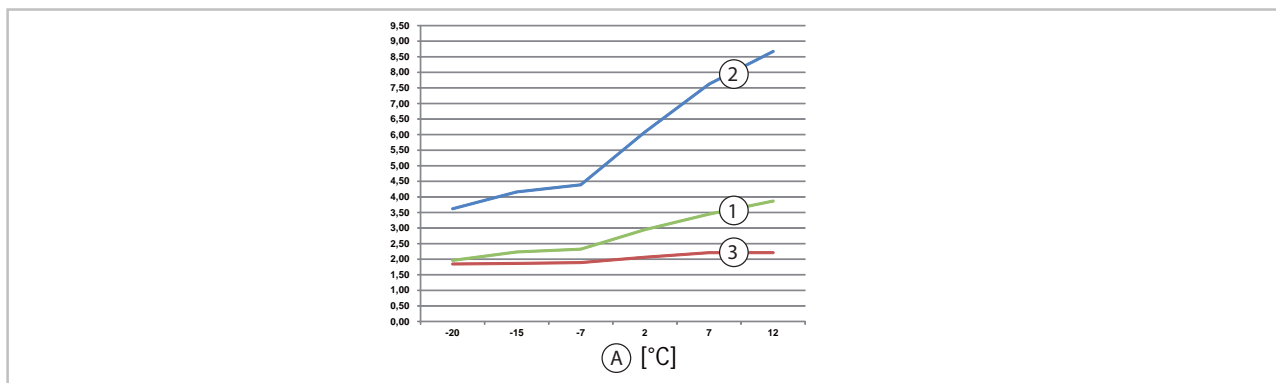

Fig. 8: Performance curves, heating RVT 684 DC (data for room temperature 20 °C)

- A: Outside temperature
- 1: COP
- 2: Heating capacity in kW
- 3: Power consumption in kW

Outside temperature in °C	-20	-15	-7	2	7	12
Heating capacity in kW	3.62	4.16	4.39	6.08	7.62	8.67
Power consumption in kW	1.85	1.87	1.89	2.06	2.21	2.21
COP	1.96	2.23	2.32	2.95	3.45	3.87

### Cooling capacity RVT 684 DC

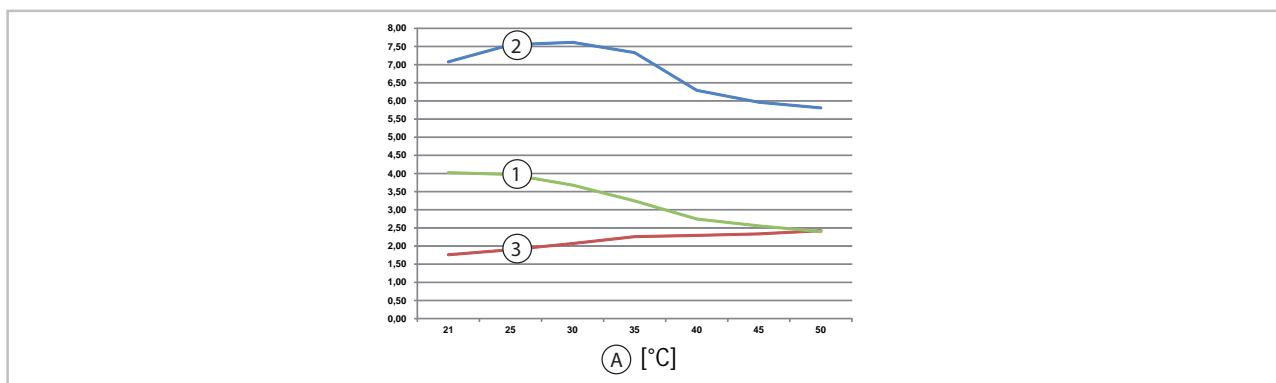

Fig. 9: Performance curves, cooling RVT 684 DC (data for room temperature FK27°/TK19 °C)

- A: Outside temperature
- 1: EER
- 2: Cooling capacity in kW
- 3: Power consumption in kW

Outside temperature in °C	21	25	30	35	40	45	50
Cooling capacity in kW	7.08	7.55	7.61	7.33	6.29	5.96	5.81
Power consumption in kW	1.76	1.90	2.07	2.26	2.29	2.33	2.42
EER	4.02	3.97	3.68	3.24	2.74	2.55	2.40

# REMKO RVT-ARCTIC series

## 3 Design and function

### 3.1 Characteristics of REMKO inverter air conditioner with split design

#### REMKO inverter technology

The air conditioner's condenser is equipped with a requirement-dependent speed control system. The power control on conventional air conditioners provides only two states, either ON (full output) or OFF (no output). The air conditioner turns on below a specified temperature and turns off when this temperature is reached. This kind of heat regulation is very inefficient. Heat regulation in the Remko inverter air conditioner is modulated to the actual need. The electronics system has an integrated frequency-converter which serves to modify the condenser speed and the speed of the blower as required. The condenser works at a higher

speed when under full load than under partial load. The lower speeds ensure a longer operational life-time for the components, improved coefficient of performance and lower noise. Lower speeds also result in lower energy consumption (electricity) and longer service life. I.e.: inverter air conditioner will run practically throughout the cooling season. In all, the highest efficiency possible.



*Thanks to innovative inverter technology, this air conditioner will almost always operate by adapting its cooling capacity to the actual requirements of the cooling season, and will in fact turn itself off when heat is removed. The same applies in the opposite direction with heating.*

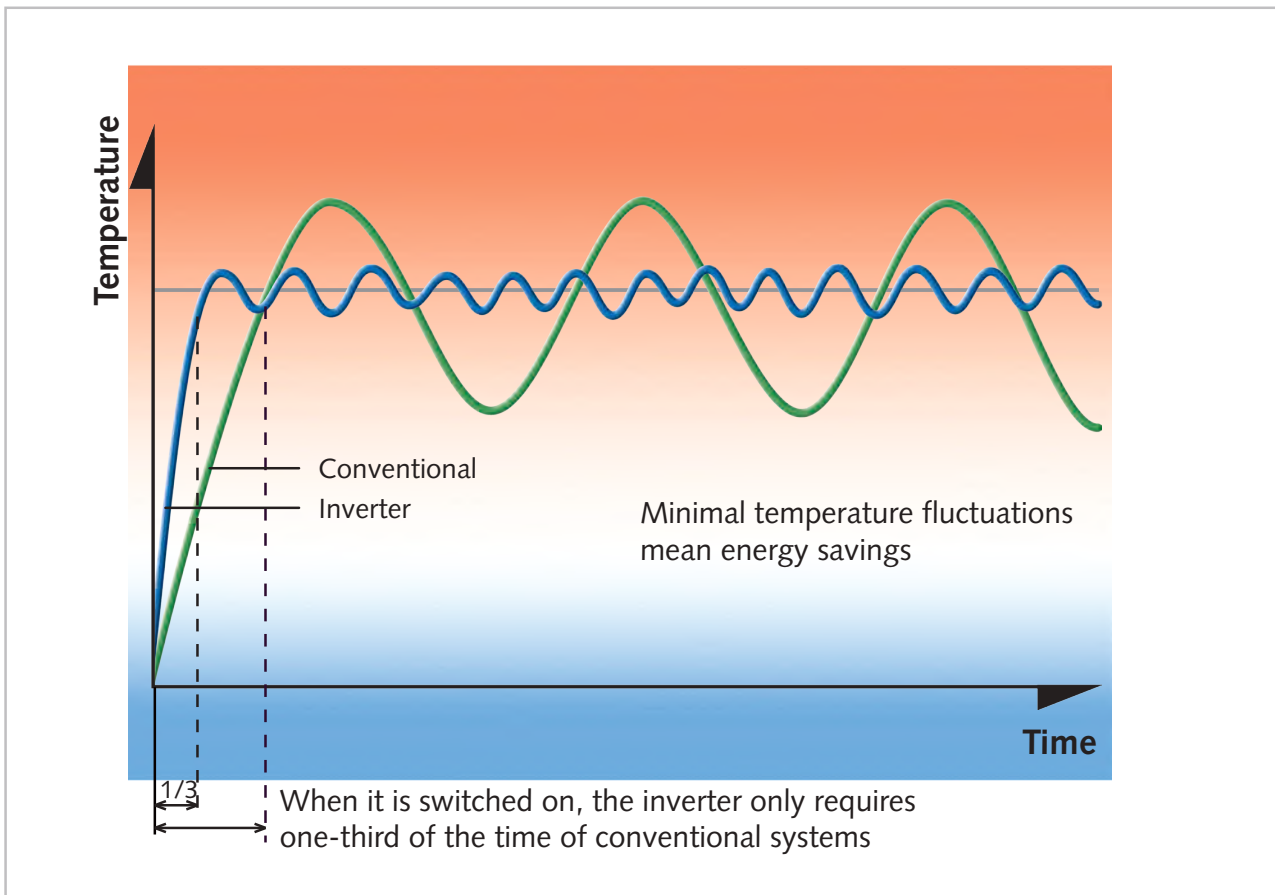

Fig. 10: Modern inverter technology

### Cooling mode

Because of circuit reversal, heating is also possible. In heating mode, the components of the refrigeration circuit are used to produce warm air thus in the building can be heated.

The comfort zone in the illustration below shows which values for temperature and humidity are considered comfortable for people. This range should ideally be met when heating or air-conditioning buildings.

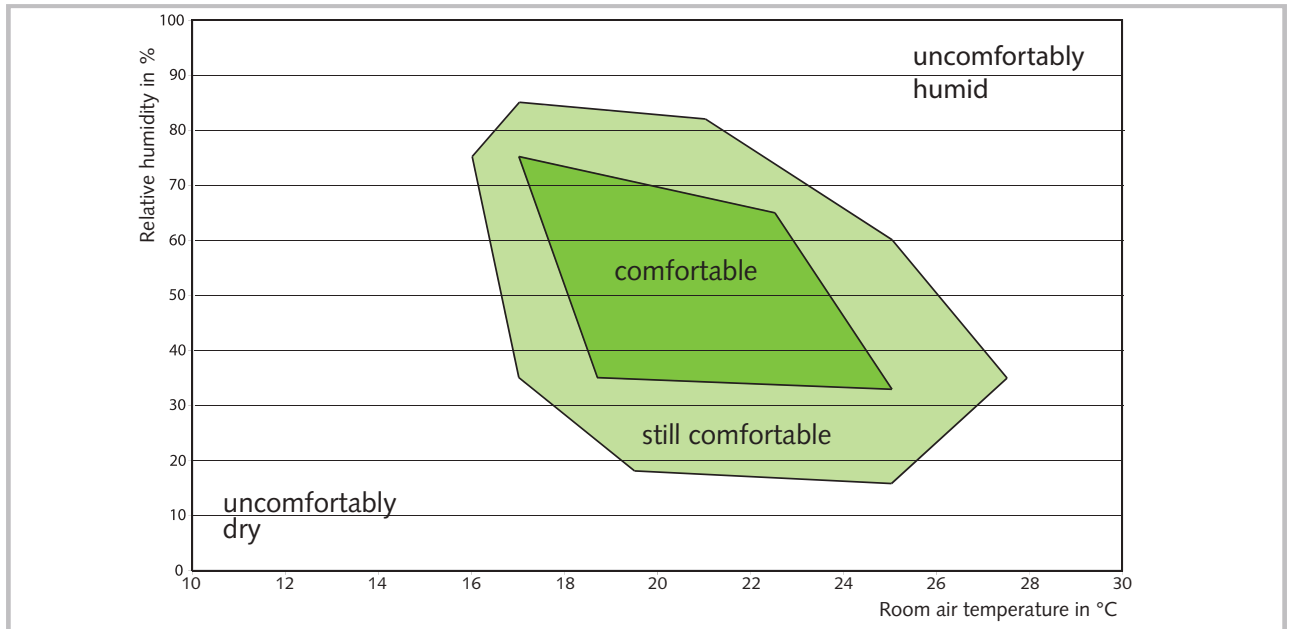

Fig. 11: Comfort zone

# REMKO RVT-ARCTIC series

## 3.2 Unit description

The RVT 264-684 DC room air conditioners have a REMKO RVT...AT outdoor unit as well as an RVT...IT indoor unit.

In cooling mode, the outdoor unit serves to output the heat extracted by the indoor unit from the room being cooled. In heating mode, the heat taken up by the outdoor unit can be discharged by the indoor unit into the room to be heated. In both operating modes, the output produced by the compressor precisely matches requirements, and thereby regulates the nominal temperature with minimal temperature deviations. This "inverter technology" results in energy savings over conventional split systems and also reduces noise emissions to a particularly low level. The outdoor unit can be installed in an outdoor area or, providing that certain requirements are met, an indoor area. The indoor unit is designed to be mounted high up on the wall, in indoor areas. It is operated by an infrared remote control.

The outdoor unit consists of a cooling cycle with compressor, fin condenser, condenser fan, reversing valve and throttle element. The outdoor unit is controlled by the controller in the indoor unit.

The indoor unit consists of a fin evaporator, evaporator fan, controller and condensate tray.

Floor brackets, wall brackets, refrigerant piping and condensate pumps are available as accessories.

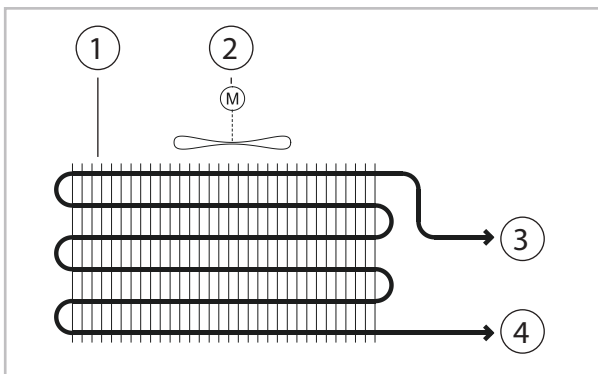

Fig. 12: Cooling cycle diagram for indoor unit

- 1: Evaporator
- 2: Evaporator fan
- 3: Suction pipe connection
- 4: Injection pipe connection

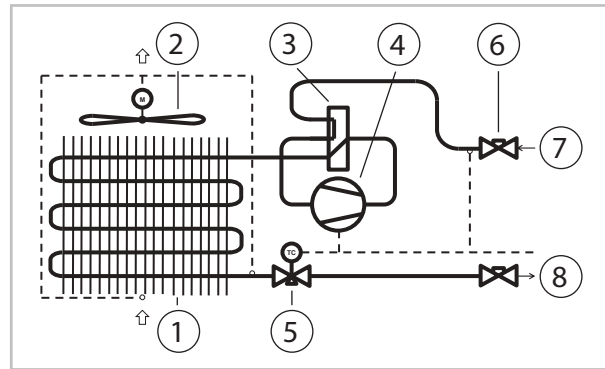

Fig. 13: Cooling cycle diagram for outdoor unit

- 1: Condenser
- 2: Condenser fan
- 3: Reversing valve
- 4: Compressor
- 5: Capillary tube injection
- 6: Pressure gauge connection
- 7: Suction pipe connection valve
- 8: Injection pipe connection valve

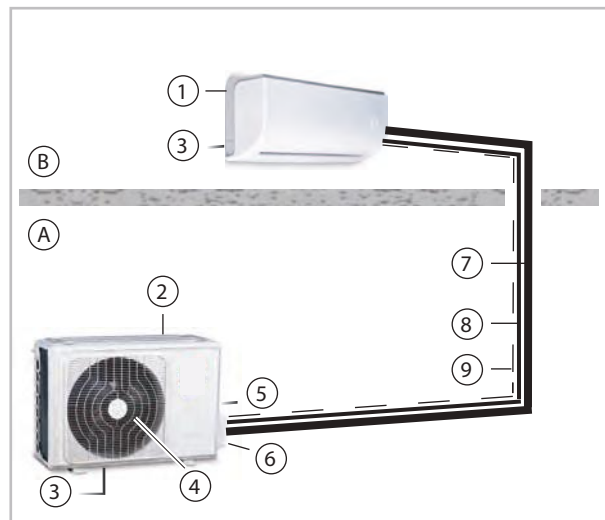

Fig. 14: System layout

- A: Outdoor area
- B: Indoor area
- 1: Indoor unit
- 2: Outdoor unit
- 3: Condensate drainage line
- 4: Condenser fan
- 5: Power supply
- 6: Shut-off valve
- 7: Suction pipe
- 8: Injection pipe
- 9: Control line

Refrigerant piping is used to connect the indoor unit to the outdoor unit.

## 4 Operation

### 4.1 General notes

The indoor unit is easily operated using the standard infrared remote control. The indoor unit beeps to acknowledge the correct transmission of data. If it is not possible to program the indoor unit with the remote control, then it can also be manually operated.

#### Manual mode

The indoor unit can also be switched on manually if the infrared remote control is lost/defective. Manual operation is intended for emergency operation and is not suitable for basic unit operation. Please replace the remote control. The key for manual activation is located on the right side of the unit.

The following settings apply for manual operation:

Pressing once: Automatic mode,

Pressing twice: Cooling mode,

Pressing three times: Unit OFF

#### Infrared remote control

The infrared remote control sends the programmed settings a distance of up to 6 m to the receiver of the indoor unit. Data will only be received correctly if the remote control is pointed at the receiver and no objects are obstructing the transmission path.

Two AAA batteries must be inserted into the remote control in preparation. To do so, remove the flap from the battery compartment and insert the batteries the correct way around (see markings). Removing the batteries causes all stored data to be lost. The remote control will then access the default settings, which you are free to customise at any time.



Fig. 15: Maximum distance



Alarms are indicated by a code (see chapter *Troubleshooting and customer service*).

#### ! NOTICE!

Immediately replace flat batteries with a new set, otherwise there is a risk of leakage. It is recommended that the batteries are removed if the equipment is shut down for longer periods.



Help save on energy consumption in stand-by mode! If the device, system or component is not in use, we recommend disconnecting the power supply. Components with a safety function is excluded from our recommendation!

### 4.2 Display on indoor unit

#### Display



1: Display of coded error message and target temperature

# REMKO RVT-ARCTIC series

## 4.3 Keys on the remote control



Fig. 16: Keys on the remote control

### ① "ON/OFF" key

Press this key to switch the air conditioning unit on and off.

### ② Operating mode selection

This key is used to set the desired operating mode. The automatic, cooling, dehumidification, heating and recirculation modes are available.

### ③ Fan speed

Use this key to select the desired fan speed. The automatic, low, medium and high functions are available. Note: In the dehumidification mode, the fan speed cannot be set manually.

### ④ "SLEEP" key

Activates/deactivates the "SLEEP" function.

Pressing this key will automatically increase or decrease the target temperature by 1 °C within an hour in cooling and heating mode respectively. Press this key to maintain the most convenient temperature and save energy. This function is only available in "Cooling", "Heating" and "Auto" modes. If the unit is working in "SLEEP" mode, this activity is interrupted by pressing the "MODE", "FAN", "Speed" or "ON/OFF" keys.

### ⑤ "FRESH" key (not available)

Press this key to activate/deactivate the ion generator (air freshener).

### ⑥ "TURBO" key

Activation of the turbo function makes it possible to reach the setpoint in cooling or heating mode as fast as possible.

### ⑦ "SELF CLEAN" key

The self-clean function can be activated in the cooling or dehumidification mode. It is used to dry the evaporator after long operating periods. This is to prevent mould and odours. The unit enters the recirculation mode for a short time after activation, heats up briefly after a few minutes and then switches back into the recirculation mode.

### ⑧ "ARROW UP" and "ARROW DOWN" keys

"ARROW UP" key

Press the key in order to increase the setpoint in 1 °C steps to a maximum 30°C.

"ARROW DOWN" key

Press the key in order to reduce the setpoint in 1°C steps to a minimum 17°C.

### ⑨ "SILENCE/FP" key

Activates/deactivates the silent mode. Pressing the key for longer than 2 seconds activates the unit's frost protection function.

In silent unit mode, the compressor runs at a lower frequency, and the indoor unit fan rotates at a slower speed. This obtains particularly silent unit operation.

The frost protection function can only be activated in heating mode. The unit operates with a fixed setpoint of 8°C. The indoor unit displays "FP". Pressing the ON/OFF, SLEEP, FP, Mode, FAN or up or down arrow key, the frost protection function is deactivated.

### ⑩ "TIMER ON" key

Press this key to activate the unit start delay time. Each press of this key increases the delay time by 30 minutes. When the set time on the display exceeds 10.0, each press of the button increases the set time by 60 minutes. To deactivate the delay time, set the time to 0.0.

### ⑪ "TIMER OFF" key

This key can be used to program the delayed switch-off time. Each press of this key increases the switch-off time by 30 minutes. When the set time on the display exceeds 10.0, each press of the button increases the set time by 60 minutes. To deactivate the switch-off time, set the time to 0.0.

### ⑫ 3-D swing mode

Press this key to start or stop the swing mode. With the 2-point key, you can adjust the horizontal fin on the left side and the vertical fin on the right side. Press this key once to change the angle by 6 degrees. Pressing the key for 2 seconds stops the swing function. When the swing function is stopped, LC appears on the display for three seconds.

### ⑬ "FOLLOW ME" key

This key can be used to activate/deactivate the FOLLOW ME function. In this mode, the room temperature is measured on the remote control. This sends a signal to the indoor unit every 3 minutes. If the remote control does not send a signal to the indoor unit for 7 minutes, this mode is automatically deactivated.

### ⑭ "LED" key

This activates/deactivates the display on the indoor unit.

### Indicators on the LCD

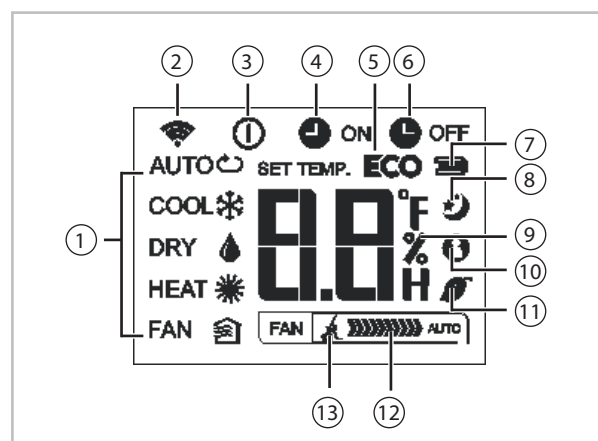

Fig. 17: Indicators on the LCD

- 1: Mode indicator - shows the current operating modes, including Auto (↻), Cooling (\*), Dehumidification (💧), Heating (\*), Fan (🌀) and back to Auto (↻) mode.
- 2: Signal transmission symbol. This symbol appears when signals are being transmitted from the remote control to the indoor unit.
- 3: ON/OFF symbol. This symbol appears when the "ON/OFF" key is pressed. Pressing this key again causes the indicator to go out.
- 4: TIMER ON symbol. This symbol appears when TIMER ON is switched on.
- 5: ECO function (not available)
- 6: TIMER OFF symbol. This symbol appears when TIMER OFF is switched on.
- 7: Battery charge status (weak)
- 8: Sleep symbol. This symbol appears when the "Sleep" function is activated. Pressing this key again causes the indicator to go out.
- 9: Temperature/Timer symbol. Shows the temperature setting (-17°C~30°C). If "FAN" mode is selected, the temperature setting is not displayed. In Timer mode, the ON and OFF settings appear for the TIMER.
- 10: FOLLOW ME symbol. This symbol appears when the "Follow me" function is activated.
- 11: Display of ion generator active (optional)
- 12: Fan speed symbol. This is where the selected fan speeds are displayed: AUTO (no indicator) and the three fan speed settings: 🌀 (slow), 🌀🌀 (medium) and 🌀🌀🌀 (fast). The fan speed is set to "Automatic" when either "Auto" or "Dehumidification" mode is activated.
- 13: Silent mode active (optional)

# REMKO RVT-ARCTIC series



The illustration of the LCD with all of the symbols present is only intended to provide a clearer overview. During operation, only those symbols relevant to the respective functions appear on the display.

## Key functions

A symbol is shown on the display to indicate that the settings are being transferred.

### "Auto" mode (please observe notes!)

Make sure that the indoor unit is connected to the power supply, and is switched on.

The operating mode indicator on the display of the indoor unit begins to flash.

1. Press the **"MODE"** key to select "Auto" mode.
2. Press the **"Arrow up/down"** key to set the desired temperature. The temperature can be set between 17 and 30°C, in increments of 1°C.
3. Press the **"ON/OFF"** key to switch on the air conditioning unit.



Fig. 18: "Auto" mode

1. Press the **"MODE"** key to select from operating modes "Cooling", "Heating" or "Recirculation".
2. Press the **"Arrow up/down"** key to set the desired temperature. The temperature can be set between 17 and 30°C, in increments of 1°C.
3. Press the **"FAN"** key to select from the four fan speeds (Auto, slow, medium and fast).
4. Press the **"ON/OFF"** key to switch on the air conditioning unit.



Fig. 19: "Cooling", "Heating" and "Recirculation" mode

### "Cooling", "Heating" and "Recirculation" mode

Make sure that the indoor unit is connected to the power supply, and is switched on.



### "Dehumidification" mode

Make sure that the indoor unit is connected to the power supply, and is switched on.

The operating mode indicator on the display of the indoor unit begins to flash.

1. ➤ Press the **"MODE"** key to select "Dehumidification" mode.
2. ➤ The temperature setting on the remote control has no effect on unit operation.
3. ➤ Press the **"ON/OFF"** key to switch on the air conditioning unit.



Fig. 20: "Dehumidification" mode



*In the "Dehumidification" mode, manual selection of the fan speed is not possible! Please note that temperature pre-selection is not possible and the dehumidified room can cool dramatically!*

### "Timer" mode

Press the "TIMER ON" key to set the "switch-on time" and the "TIMER OFF" key to set the "switch-off" time for the unit.

Setting the "switch-on time"

1. ➤ Press the "TIMER ON" key. The remote control shows "TIMER ON", the last "switch-on time" setting and the symbol "H" appear on the display. The unit is now ready to reset the "switch-on time" and to start "TIMER ON" mode.
2. ➤ Press the "TIMER ON" key again to set the desired "switch-on time". Each time the key is pressed, the time is increased by half an hour between 0 and 10 hours, and by an hour between 10 and 24 hours.
3. ➤ Once these settings have been made, there is a one second delay before the remote control transmits the signal to the indoor unit. Then, after approx. two seconds, the "H" symbol disappears from the LCD display, and the set temperature appears again on the display.

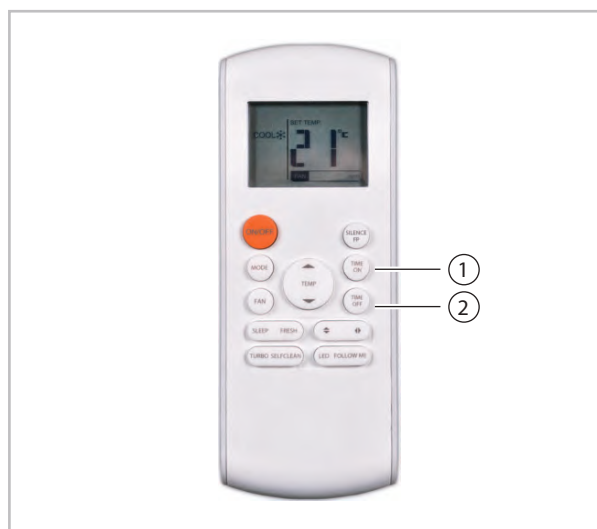

Fig. 21: "Timer" mode

# REMKO RVT-ARCTIC series

## Setting the "switch-off time"

1. ➤ Press the "TIMER OFF" key. The remote control shows "TIMER OFF", the last "switch-off time" setting and the symbol "H" appear on the display. The unit is now ready to reset the "switch-off time" and to stop "TIMER OFF" mode.
2. ➤ Press the "TIMER OFF" key again to set the desired "switch-off time". Each time the key is pressed, the time is increased by half an hour between 0 and 10 hours, and by an hour between 10 and 24 hours.
3. ➤ Once these settings have been made, there is a one second delay before the remote control transmits the signal to the indoor unit. Then, after approx. two seconds, the "H" symbol disappears from the LCD display, and the set temperature appears again on the display.



- When Timer mode is selected, the remote control automatically transfers the timer signal to the indoor unit for the specified period of time. Therefore, you should hold the remote control in a location where it can transfer the signal to the indoor unit without interference.
- The effective operation for the time settings by the remote control for the timer function is restricted to the following settings:  
0.5, 1.0, 1.5, 2.0, 2.5, 3.0, 3.5, 4.0, 4.5, 5.0, 5.5, 6.0, 6.5, 7.0, 7.5, 8.0, 8.5, 9.0, 9.5, 10, 11, 12, 13, 14, 15, 16, 17, 18, 19, 20, 21, 22, 23 and 24.

## Example TIMER function settings

### "TIMER ON" (Auto on mode)

#### Example:

You want the air conditioning unit to switch on 2 hours from the time it was programmed

1. ➤ Press the "TIMER ON" key. The last operating time setting for the timer, and the "H" symbols, appear on the display.
2. ➤ Press the "TIMER ON" key until the desired start time is shown in the "TIMER ON" area on the remote control.
3. ➤ Wait for 3 seconds and the temperature appears again in this area of the digital display. The "TIMER ON" indicator stays lit, and this function is activated.

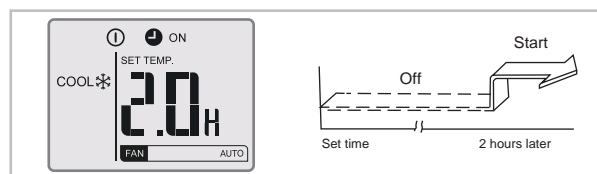

Fig. 22: "TIMER ON" example

### "TIMER OFF" (Auto off mode)

#### Example:

You want the air conditioning unit to switch off 4 hours from the time it was programmed.

1. ➤ Press the "TIMER OFF" key. The last operating time setting for the timer, and the "H" symbols, appear on the display.
2. ➤ Press the "TIMER OFF" key until "10H" is shown in the "TIMER OFF" area on the remote control.
3. ➤ Wait for 3 seconds and the temperature appears again in this area of the digital display. The "TIMER OFF" indicator stays lit, and this function is activated.

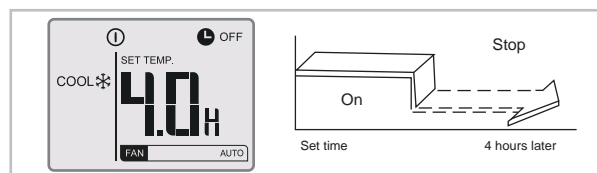

Fig. 23: "TIMER OFF" example

### Combined TIMER (setting "TIMER ON" and "TIMER OFF" at the same time)

"TIMER OFF" ⇨ "TIMER ON"

(On ⇨ Stop ⇨ Start)

#### Example:

You want the air conditioning unit to switch off in two hours from the time it was programmed, and switch back on ten hours later.

1. ➤ Press the "TIMER OFF" key.
2. ➤ Press the "TIMER OFF" key again until the desired stop time is shown in the "TIMER OFF" area on the remote control.
3. ➤ Press the "TIMER ON" key.
4. ➤ Press the "TIMER ON" key again until "10H" is shown in the "TIMER ON" area on the remote control.
5. ➤ Wait for 3 seconds and the temperature appears again in this area of the digital display. The "TIMER ON" and "TIMER OFF" indicators stay lit, and this function is activated.

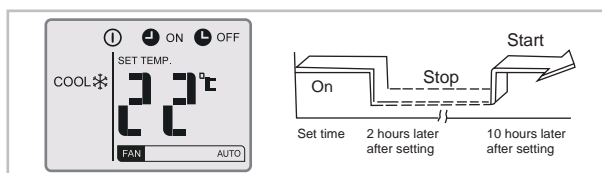

Fig. 24: "TIMER OFF" / "TIMER ON" example

"TIMER ON" ⇨ "TIMER OFF"

(Off ⇨ Start ⇨ Stop)

#### Example:

You want the air conditioning unit to switch on in two hours from the time it was programmed, and switch back off five hours later.

1. ➤ Press the "TIMER ON" key.
2. ➤ Press the "TIMER ON" key again until "2.0H" is shown in the "TIMER ON" area on the remote control.
3. ➤ Press the "TIMER OFF" key.
4. ➤ Press the "TIMER OFF" key again until "5.0H" is shown in the "TIMER OFF" area on the remote control.
5. ➤ Wait for 3 seconds and the temperature appears again in this area of the digital display. The "TIMER ON" and "TIMER OFF" indicators stay lit, and this function is activated.

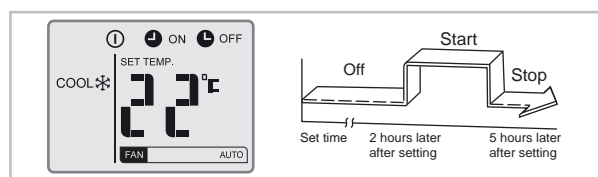

Fig. 25: "TIMER ON" / "TIMER OFF" example

# REMKO RVT-ARCTIC series

## SLEEP function

The sleep function saves energy while you sleep. This function is activated by pressing the key on the remote control. Press the key before going to sleep. In cooling mode, the unit automatically increases the set room temperature by 1 °C after 1 hour. After one more hour, the room temperature is increased by an additional 1 °C. In heating mode, the room temperature is decreased within the first two hours of operation by 2°C. After 7 hours of unit operation, the unit switches off automatically in cooling and heating mode.

This function is not available in the modes recirculation and dehumidification!



Fig. 26: "Sleep" function

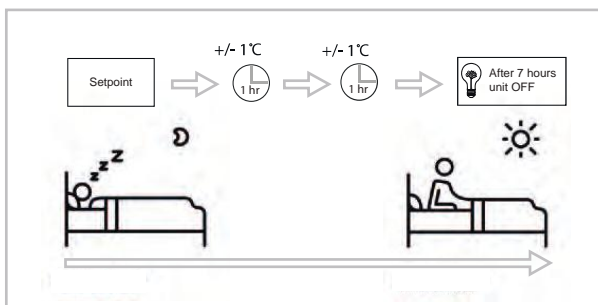

Fig. 27: Sleep mode

## 5 Installation instructions for qualified personnel

### 5.1 Important notes prior to installation

- Transport the unit in its original packaging as close as possible to the installation location. You avoid transport damage by doing so.
- Check the contents of the packaging for completeness and check the unit for visible transport damage. Report any damage immediately to your contractual partner and the shipping company.
- Lift the unit on the corners and not on the refrigerant or condensate drainage connections.
- The refrigerant piping (liquid and suction pipe), valves and connections must be insulated to make them vapour diffusion proof. If necessary also insulate the condensate drainage line.
- Select an installation location which allows air to freely flow through the air inlet and outlet (see section "Minimum clearances").
- Do not install the unit in the immediate vicinity of devices which generate intensive thermal radiation. Installation in the vicinity of thermal radiation reduces the unit output.
- Only open the shut-off valves on the refrigerant piping after installation is complete.
- Seal off open refrigerant piping with suitable caps or adhesive strips to prevent the infiltration of moisture and never kink or compress the refrigerant piping.
- Avoid unnecessary bends. This minimises the pressure loss in the refrigerant piping and ensures that the compressor oil can flow back without obstruction.
- Make special preparations regarding the oil return if the outdoor unit is located above the indoor unit (see section "Oil return measures").
- Add refrigerant if the basic length of the refrigerant piping exceeds 5 metres. For the quantity of additional refrigerant, refer to chapter "Adding refrigerant".
- Perform all electrical wiring in accordance with applicable DIN and VDE standards.
- Ensure the electrical cables are properly connected to the terminals, otherwise there is a risk of fire.
- Use four supports and the associated hooks to attach the ceiling cassette (only applies to ceiling cassettes).
- Use the insulated condensate hose in the scope of delivery as a junction piece to the continuing condensate drain. Secure the condensate drain with the supplied clamps.

### 5.2 Wall openings

- A wall opening of at least 70mm diameter and 10mm incline from the inside to the outside must be created.
- To prevent damage to the lines, the interior of the wall opening should be padded or, for example, lined with PVC pipe (see figure).
- After installation has been completed, use a suitable sealing compound to close off the wall opening, taking account of fire protection regulations (responsibility of customer). Do not use cement or lime containing substances!

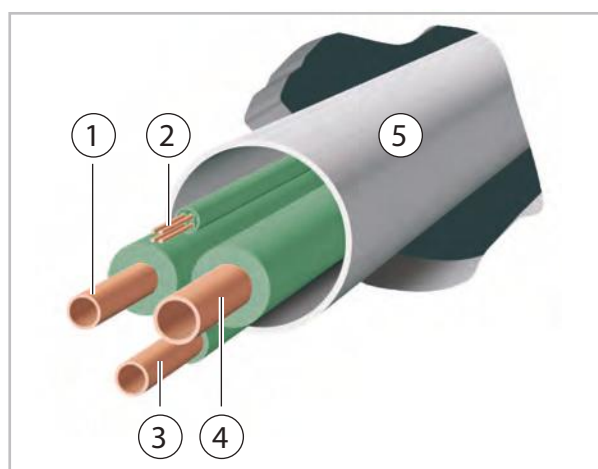

Fig. 28: Wall opening

- 1: Liquid line
- 2: Control line
- 3: Condensate drainage line
- 4: Suction pipe
- 5: PVC pipe

### 5.3 Installation materials

The indoor unit is attached to the wall by a wall bracket and 4 screws (to be provided by the customer).

The outdoor unit is attached by 4 screws and a wall bracket to the wall or fixed by a floor bracket to the ground.

### 5.4 Layout, indoor unit

The indoor unit is designed for horizontal wall installation above doors. However, it can also be used in the upper wall area (min. 1.75 m above the floor).

The minimum room size must be 4 m<sup>2</sup>.

This varies according to the total fill quantity of the system. Observe the valid DIN standards for the calculation!

# REMKO RVT-ARCTIC series

## 5.5 Installation, mounting outdoor unit

### Outdoor unit installation location

- The device may be attached only to a load-bearing structure or wall. Ensure that the outdoor unit is installed only vertically. The installation site should be well ventilated.
- To minimise noise, install floor consoles with vibration dampers and a considerable distance from acoustically-reflective walls to minimise noise.
- The minimum clearances specified on the next page should be maintained when carrying out the installation. These minimum distances serve to ensure unrestricted air intake and exhaust. Additionally, there must be adequate space available for installation, maintenance and repair.
- If the outdoor unit is erected in an area of strong winds, then the device must be protected against them (Fig. 29). The snow line is to be observed during installation (Fig. 30).
- The outdoor unit must always be installed on vibration dampers. Vibration dampers prevent the transmission of vibrations through the floor or walls.
- A heated, condensate tray ensures that condensation from the pan can drain off. Ensure that the condensate is prevented from freezing so that it can drain off (gravel, drainage). The Water Ecology Act is to be observed.
- The outdoor unit must always be installed outdoors. Do not install the outdoor unit in enclosed rooms, including basement and window shafts.

- During installation, add about 20 cm to the expected snow depth to guarantee unimpeded intake and exhaust of outdoor air year round (Fig. 30).
- The installation site of the outdoor unit should be agreed together with the operator primarily so that operating noise is minimised and not in terms of “short routes”. Thanks to the split-design technology there are a great deal of different installation options with almost identical efficiency available.

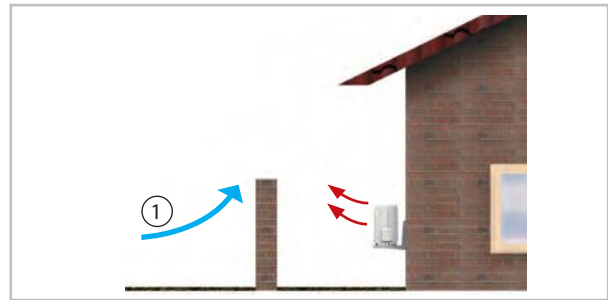

Fig. 29: Protection from wind

1: Wind

### ! NOTICE!

The site for the outdoor unit must be selected so that machinery noise that occurs disturbs neither the residents nor the facility operator. Observe the TA-noise specifications as well as the table containing the drawings relating to sound pressure levels..

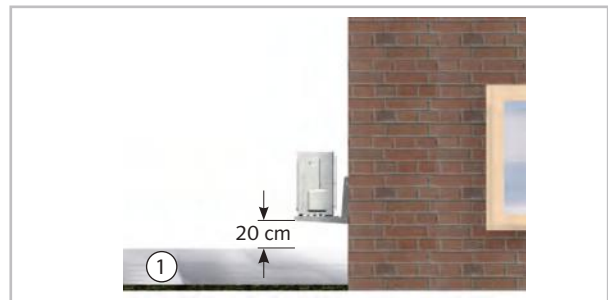

Fig. 30: Protection from snow

1: Snow

Point of emissions	Assessment level in accordance with TA noise	
	days in dB(A)	nights in dB(A)
Industrial areas	70	70
Commercial areas	65	50
Core areas, village areas and mixed zones	60	45
General residential areas and small housing estates	55	40
Exclusively residential areas	50	35
Spa areas, hospitals and mental institutions	45	35

Isolated noise peaks of short duration may not exceed 30 dB(A) during the day and 20 dB(A) at night.

### Definition of the Danger Area

 **WARNING!**

Access to the unit is only permitted for authorised and trained persons. If unauthorised persons can approach the danger areas, these areas must be identified with corresponding signs, barriers, etc.

- The external danger area surrounds the equipment up to a distance of 2 m, measured in all directions from the unit housing.
- The external danger area on-site can differ as a result of the setup. The specialist company performing the installation work bears the responsibility for this.
- The internal danger area is located inside the machine and can only be reached with the use of an appropriate tool. Access is prohibited for unauthorised persons!

# REMKO RVT-ARCTIC series

## 5.6 Minimum clearances

Observe the minimum clearances to allow access for maintenance and repair work and facilitate optimum air distribution.

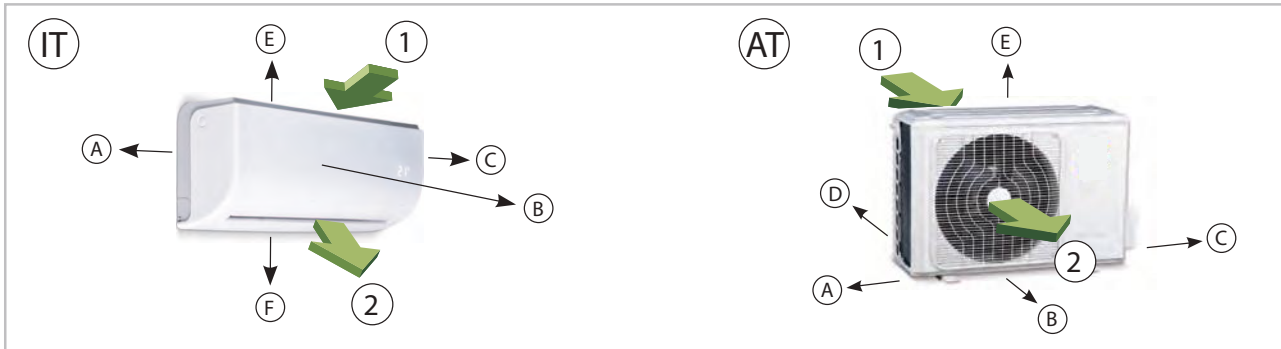

Fig. 31: Minimum clearances of the indoor unit and outdoor unit

AT: Outdoor unit

IT: Indoor unit

1: Air inlet

2: Air outlet

Dimensions (mm)	Indoor units	Outdoor units
	RVT 264-684 DC IT	RVT 264-684 DC AT
A	120	300
B	1500	2000
C	120	600
D	-	300
E	150	600
F	300	-



## 5.7 Oil return measures

If the outdoor unit is installed at a higher level than the indoor unit, suitable oil return measures must be taken. Usually, an oil pump bend is installed for every 7 metres of height difference.

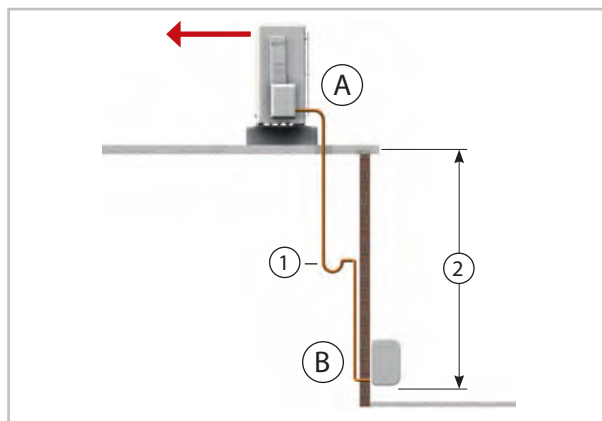

Fig. 32: Oil return measures

A: Outdoor unit

B: Indoor unit

1: One oil pump bend in suction pipe to outdoor unit every 7 metres of height difference, radius: 50 mm

2: Max. 10 m

## 5.8 Connection variants for the indoor unit

The following connection variants can be used for the refrigerant, condensate and control lines.

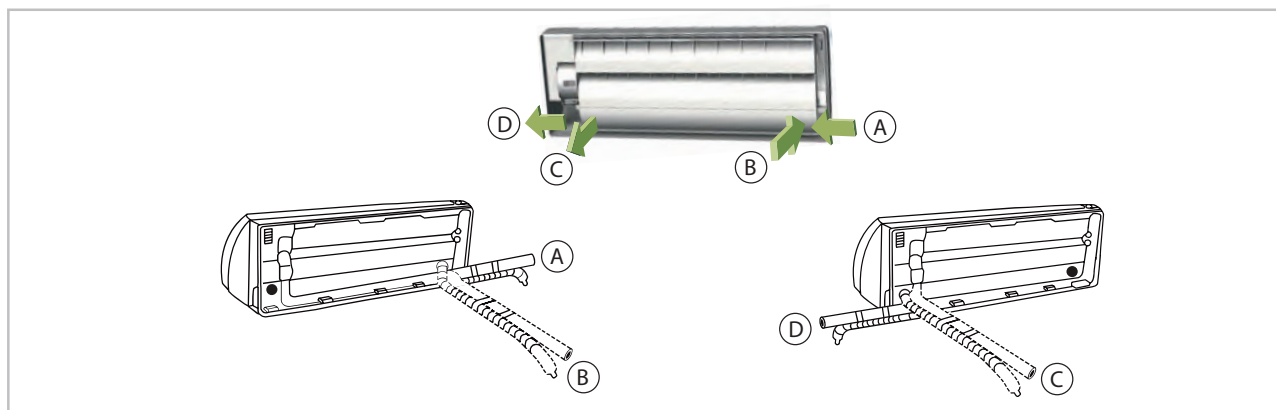

Fig. 33: Connection variant (view from the rear)

A: Infeed of the refrigerant piping at the wall, left

B: Infeed of the refrigerant piping through the wall, left

C: Outlet through the wall, right

D: Outlet at the wall, right (the refrigerant piping must be bent through 180 degrees for this)

### ! NOTICE!

A flare connection may only be established outside the room. Detachable, reusable connections are not permissible inside!

# REMKO RVT-ARCTIC series

## 5.9 Connection of the indoor unit when the refrigerant piping is installed under the plaster

If the customer routes the refrigerant piping to the unit underneath the plaster, observe the following note. The principal connection options can be found in the "Connection variants for the indoor unit" and "Wall bracket" chapters.

If the refrigerant piping is routed underneath the plaster, ensure that the customer-fitted refrigerant piping does not protrude from the wall at a 90° angle. As a result of the required bending radius, the unit would then be very difficult to connect or would possibly be impossible to fasten to the wall mount.

For this reason, route the customer-fitted refrigerant piping with as flat an angle as possible (<30°) out of the wall, from the left and into the unit. (see Fig. 34).



Fig. 34: Under the plaster installation (View from above)

## 5.10 Wall bracket for the indoor units

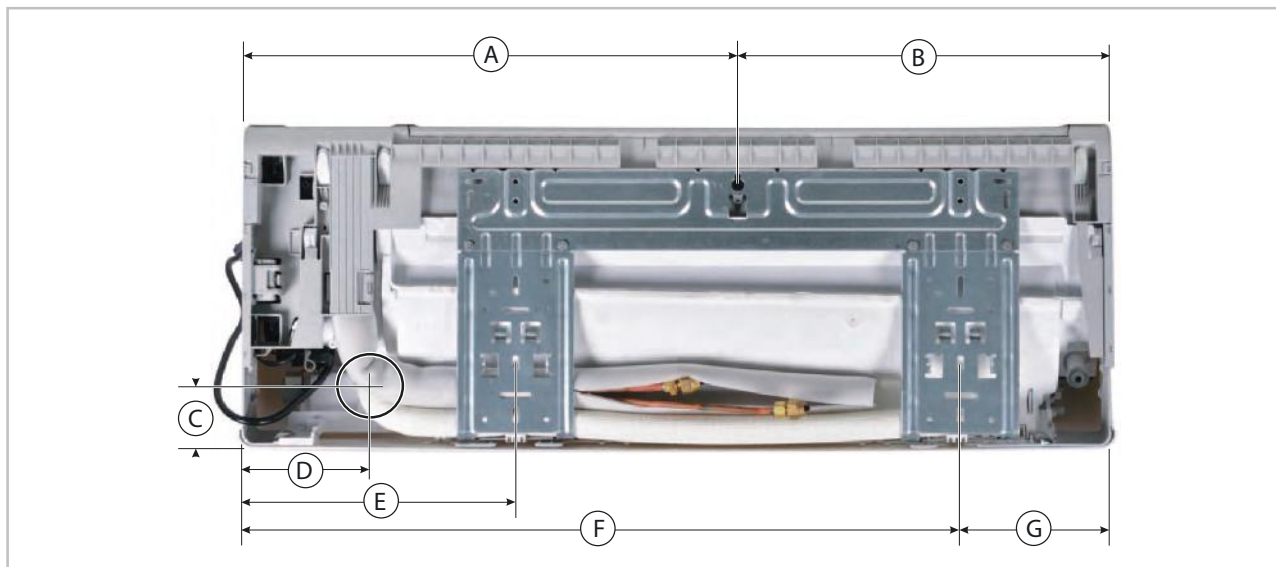

Fig. 35: Wall bracket mounting points RVT 264-684 DC (rear view)

Unit type/size (all dimensions in mm)	A	B	C	D	E	F	G
RVT 264 DC IT	382	334	75	100	225	542	174
RVT 354 DC IT	430	373	90	110	227	633	171
RVT 524 DC IT	456	508	60	115	230	680	284
RVT 684 DC IT	572	534	55	90	293	852	254

All dimensions in mm. In each case the diameter of the pipe break-through is  $\varnothing$  65 mm

The wall bracket for the units must be attached with suitable screws and anchors.

## 6 Installation

### 6.1 Installation of the indoor unit

The indoor unit is attached by means of a wall bracket, taking into consideration the air outlet side located in the lower part.

1. ➤ Mark the mounting points on the structurally permissible building sections according to the dimensions of the wall bracket.
2. ➤ If necessary, remove the break out opening of the housing.
3. ➤ Connect the refrigerant piping, electrical cables and condensate drainage line to the indoor unit as described below.
4. ➤ Hang the indoor unit onto the wall bracket by tilting it back slightly and by pressing the bottom part of the unit against the bracket.
5. ➤ Check again that the unit is level. (Fig. 36)

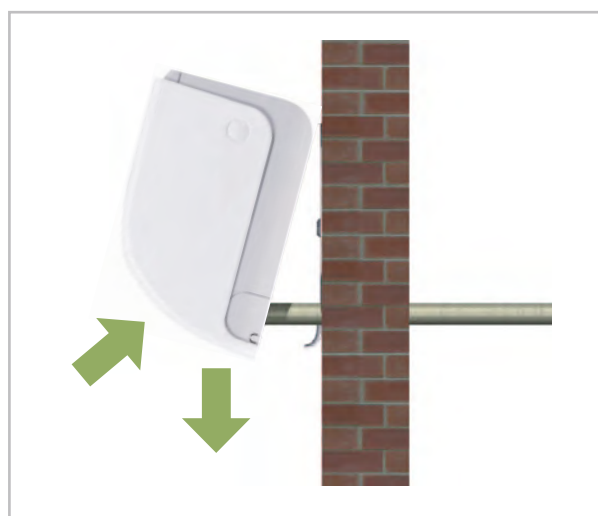

Fig. 36: Horizontal positioning

# REMKO RVT-ARCTIC series

The wall bracket for the units must be attached with suitable screws and anchors.

## 6.2 Connecting the refrigerant piping

The refrigerant piping is connected (responsibility of the customer) on the back side of the units.

Please note that a flare connection is only permissible outside the enclosed room. If this is not possible on site, the connection of the indoor unit must be established as a permanent connection (e.g. soldered).

It may be necessary to fit a reducer or flared adapter to the indoor unit. These fittings are included with the indoor unit as an accessory kit. Once installed, the connections should be insulated to make them vapour diffusion proof.

### ! NOTICE!

Installation should only be performed by authorised specialists.

### ! NOTICE!

The unit is factory filled with dry nitrogen for leak testing purposes. The pressurised nitrogen is released when the union nuts are undone.

### ! NOTICE!

Use only tools which are approved for use in an HVAC environment. (z. B.: bending pliers, pipe/tubing cutters, de-burrers and flaring tools). Do not cut refrigerant pipes with a saw.

### ! NOTICE!

All work must be carried out in a way that prevents dirt, particles, water etc. from entering, refrigerant lines!

The following instructions describe the installation of the cooling cycle and the assembly of the indoor unit and the outdoor unit.

1. ➤ The required pipe diameters are given in the table "Technical data".
2. ➤ Install the indoor unit and connect the refrigerant piping as described in the operating manual for the indoor unit.
3. ➤ Use the wall or floor brackets to fit the outdoor unit against structural parts approved to support the static load (refer to the installation instructions for the brackets).
4. ➤ Ensure that structure-borne sound is not transferred to parts of the building. Use vibration dampers to reduce the effects of structure-borne sound!
5. ➤ Lay the refrigerant piping from the indoor unit to the outdoor unit. Ensure that the fastenings are adequate and if necessary, take appropriate oil return measures!
6. ➤ Remove the factory-fitted protective caps and union nuts on the connections. These should be used later in the installation process.
7. ➤ Before flanging the refrigerant piping, ensure that the union nut is fitted on the pipe.
8. ➤ Prepare the laid refrigerant pipings as shown below (Fig. 37 and Fig. 38).
9. ➤ Verify that the shape of the flange is correct (Fig. 39).
10. ➤ First connect and hand-tighten the refrigerant piping to ensure it is correctly seated.
11. ➤ Then tighten the fittings with 2 appropriately-sized open-ended spanners. Use one spanner to counter the force when tightening the fitting (Fig. 40).
12. ➤ Use insulation hoses which are designed for this temperature range and are diffusion proof.
13. ➤ Observe the permitted bending radius for the refrigerant piping during installation. Never bend a pipe twice in the same place. Brittleness and cracking can result.
14. ➤ Apply appropriate heat insulation to the installed refrigerant piping, including connector.
15. ➤ Take the same action at the shut-off valves for all subsequent refrigerant piping.



Label the refrigerant piping (injection and suction pipes) as well as the associated electrical control lines of each interior unit with a letter. Only connect the lines to their associated connections.

**! NOTICE!**

Always pay attention to the affiliation of the electrical lines and refrigerant piping! The connections of the individual circuits must not be mixed up. Mixing up the assignment of control lines and refrigerant piping can have fatal consequences (compressor damage)!

Commissioning of the individual circuits must be carried out successively.

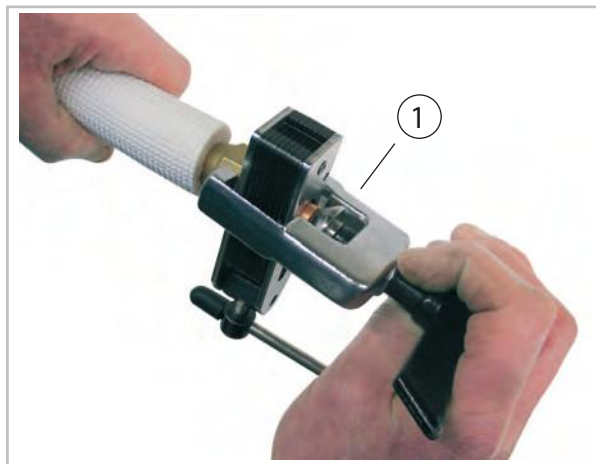

Fig. 38: Flanging the refrigerant piping

1: Flanging tool

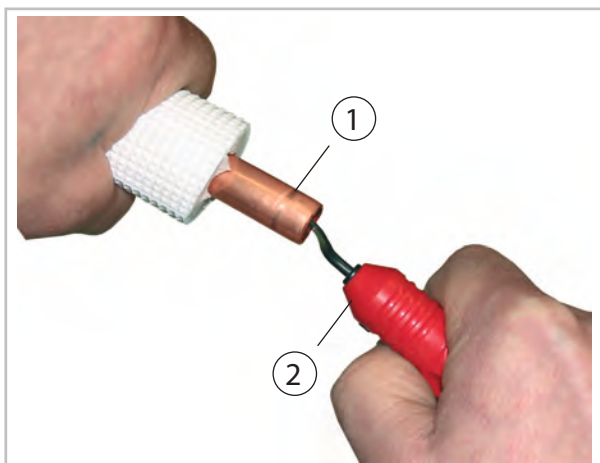

Fig. 37: Deburring the refrigerant piping

1: Refrigerant piping  
2: Deburrer

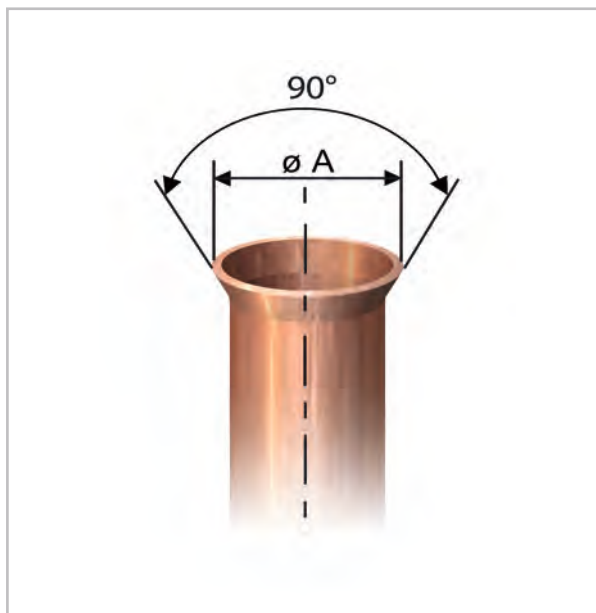

Fig. 39: Correct flange shape

# REMKO RVT-ARCTIC series

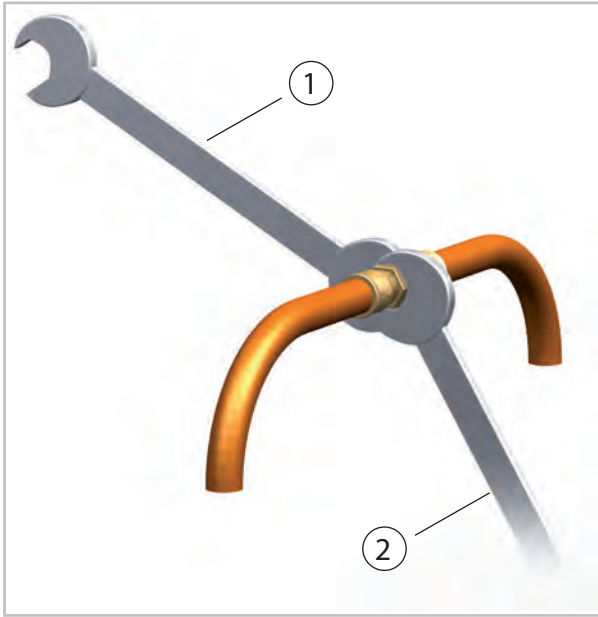

Fig. 40: Tightening the fitting

- 1: Tighten with the first open-ended spanner
- 2: Counter with the second open-ended spanner

Pipe dimension in inches	Tightening torque in Nm
1/4"	15-20
3/8"	33-40
1/2"	50-60
5/8"	65-75
3/4"	95-105

## 6.3 Additional notes on connecting the refrigerant piping

- When combining the outdoor unit with some indoor units, the procedure for connecting the refrigerant piping may differ. Install the provided reducer or expansion fittings to the indoor unit.
- If the basic length of the connecting line exceeds 5m, add refrigerant when commissioning the system for the first time (see chapter "Adding refrigerant").

## 6.4 Leak testing

Once all the connections have been made, the pressure gauge station is attached to the Schrader valve as follows (if fitted):

red = small valve = high pressure

blue = large valve = suction pressure

Once the connection has been made successfully, the leak test is carried out with dry nitrogen.

Leak testing involves spraying a leak detection spray onto the connections. If bubbles are visible, the connections have not been made properly. In that case, tighten the connection or, if necessary, create a new flange.

After completing a successful leak test, the excess pressure in the refrigerant piping is removed and a vacuum pump with an absolute final partial pressure of min. 10 mbar is used to remove all of the air and empty the pipes. Any moisture present in the pipes will also be removed.

### ! NOTICE!

A vacuum of at least 20 mbar must be produced!

The time required to generate the vacuum is dependent on the final pressure pipe volume of the indoor units and the length of the refrigerant piping. However, the process will take at least **60 minutes**. Once any foreign gases and humidity have been completely extracted from the system, the valves on the pressure gauge station are closed and the valves on the outdoor unit are opened as described in the "Commissioning" section.

## 6.5 Adding refrigerant

The units contain a basic quantity of refrigerant. In addition, an additional amount of refrigerant must be added for refrigerant piping lengths exceeding 5 metres per circuit. Refer to the following chart:

	Up to and incl. 5m	From 5m to max. length
RVT 264 DC	0 g/m	20 g/m
RVT 354 DC		
RVT 524 DC		40 g/m
RVT 684 DC		

### ⚠ CAUTION!

Wear protective clothing when handling refrigerant.

### ⚠ DANGER!

Only refrigerant in a liquid state may be used to fill the cooling cycle!

### ! NOTICE!

Check the overheating to determine the refrigerant fill quantity.

### ! NOTICE!

The escape of refrigerant contributes to climatic change. In the event of escape, refrigerant with a low greenhouse potential has a lesser impact on global warming than those with a high greenhouse potential.

This unit contains refrigerant with a greenhouse potential of 675. That means the escape of 1 kg of this refrigerant has an effect on global warming that is 675 times greater than 1 kg CO<sub>2</sub>, based on 100 years. Do not conduct any work on the refrigerant circuit or dismantle the unit - always enlist the help of qualified experts.

## 7 Condensate drainage connection and safe drainage

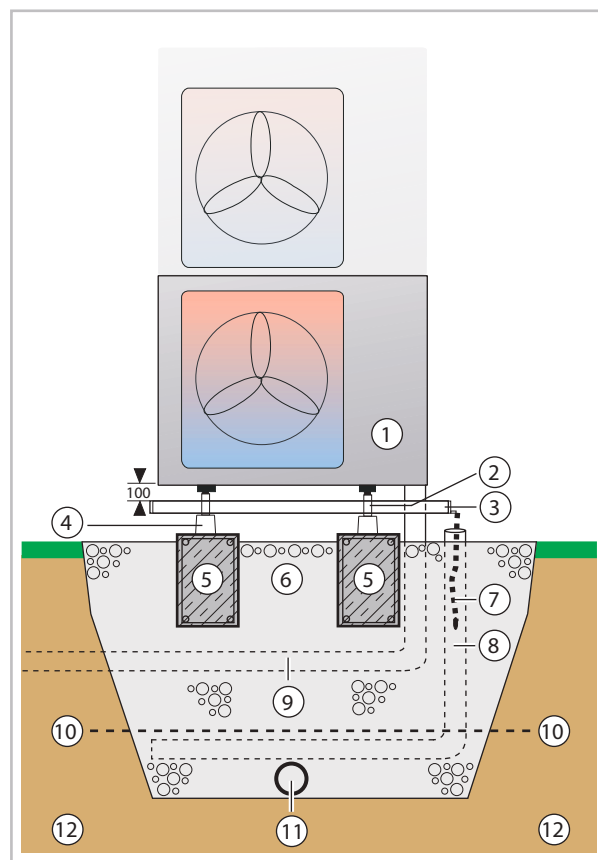

Fig. 41: Condensate drainage, seepage of condensate and strip foundation (cross-section)

- 1: Outdoor unit
- 2: Leg
- 3: Condensate collection tray
- 4: Floor bracket
- 5: Reinforced strip foundation  
HxWxD = 300x200x800mm
- 6: Gravel layer for seepage
- 7: Condensate drainage heating
- 8: Drainage channel
- 9: Conduit for refrigerant piping and electrical connecting line (temperature-resistant up to at least 60°C)
- 10: Frost line
- 11: Drainage pipe
- 12: Soil

# REMKO RVT-ARCTIC series

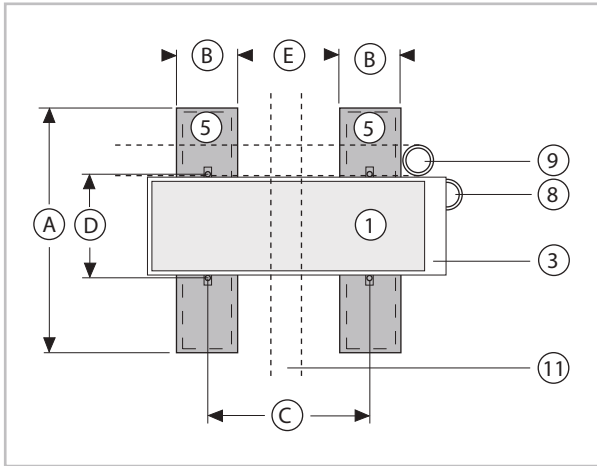

Fig. 42: Dimensions for the strip foundation (bird's eye view)

For the designations of 1,3,5,8,9 and 11, please refer to the legend for the Fig. 41

## dimensioning of the strip foundation (in mm)

Dim.	RVT 264-524 DC	RVT 264-354 DC	RVT 684 DC
A	800	800	800
B	200	200	200
C	487	514	540
D	298	340	350
E	287	314	340

## Condensate drainage connection

If the temperature falls below the dew point, condensation will form on the finned condenser during **heating mode**.

A condensate tray should be installed on the underside of the unit to drain any condensate.

- The condensate drainage line should have an incline of min. 2%. This is the responsibility of the customer. If necessary, fit vapour-diffusion-proof insulation.
- When operating the unit at outside temperatures below 4 °C, ensure the condensate drainage line is laid to protect it against frost. The lower part of the housing and condensate tray is also to be kept frost free in order to ensure permanent draining of the condensate. If necessary, fit a pipe heater.
- Following installation, check that the condensate run off is unobstructed and ensure that the line is durably leak tight.

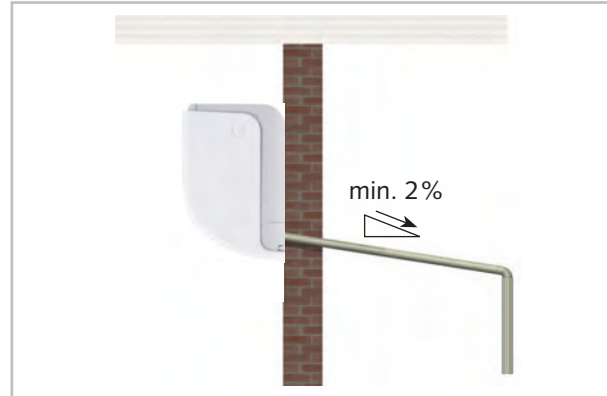

Fig. 43: Condensate drainage connection - Indoor unit

## Safe drainage in the event of leakages

The REMKO oil separator OA 2.2 fulfils the following list of requirements from regional regulations and laws.

### ! NOTICE!

Local regulations or environmental laws, for example the German Water Resource Law (WHG), can require suitable precautions to protect against uncontrolled draining in case of leakage to provide for safe disposal of escaping refrigerator oil or hazardous media.

### ! NOTICE!

If condensate is removed via a duct in accordance with DIN EN 1717, ensure that any microbiological contamination present on the wastewater side (bacteria, fungi, viruses) cannot enter the unit connected to it.



## 8 Electrical wiring

### 8.1 General Information

A protected power supply cable is to be connected to the outdoor unit and a five-core control line to the indoor unit respectively.

#### DANGER!

All electrical installation work is to be performed by specialist companies. Disconnect the power supply when connecting the electrical terminals.

#### WARNING!

All electric lines are in accordance VDE regulations to dimension and to lay.

#### NOTICE!

The electrical connection of the units must be carried out in accordance with VDE regulations. We recommend using an FI circuit breaker that is sensitive to all currents, as increased leakage currents can occur.



*We recommend using shielded wires for the control lines.*



*Check all plugged and clamped terminals to verify that they are seated correctly and make permanent contact. Tighten as required.*

### 8.2 Connecting the indoor unit

- We recommend installing a main / repair switch on the building close to the indoor unit. This is the responsibility of the customer.
- The terminal blocks for making the connections are located at the rear of the unit. When the unit is installed, measurements can be made from the front by removing the cover.
- If an optional condensate pump is used in conjunction with the unit, it may be necessary to install an additional relay with a higher contact rating after the switch-off contact on the pump to switch off the compressor.

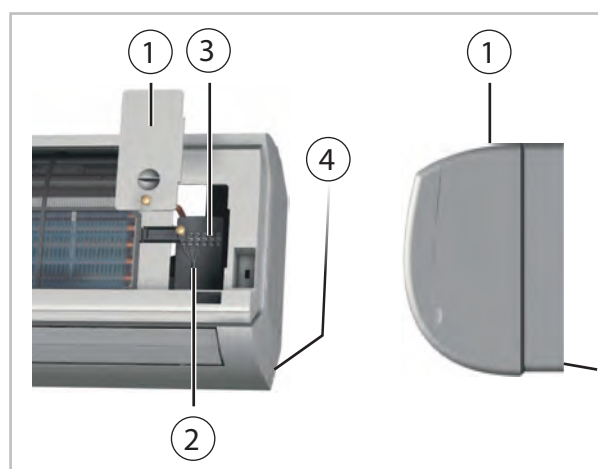

Fig. 44: Connecting the indoor unit

- 1: Cover
- 2: Strain relief
- 3: Terminal block for control line
- 4: Control line from outdoor unit

# REMKO RVT-ARCTIC series

Make the connection as follows:

1. ➤ Remove the screws [A] und [B], which are behind of the cover (see Fig. 45).
2. ➤ You can now fold up the unit cover [C] (see Fig. 46).
3. ➤ Connect the control line provided by the customer to the terminals [D] (see Fig. 47).
4. ➤ Re-assemble the unit.



Fig. 45: Remove the screws

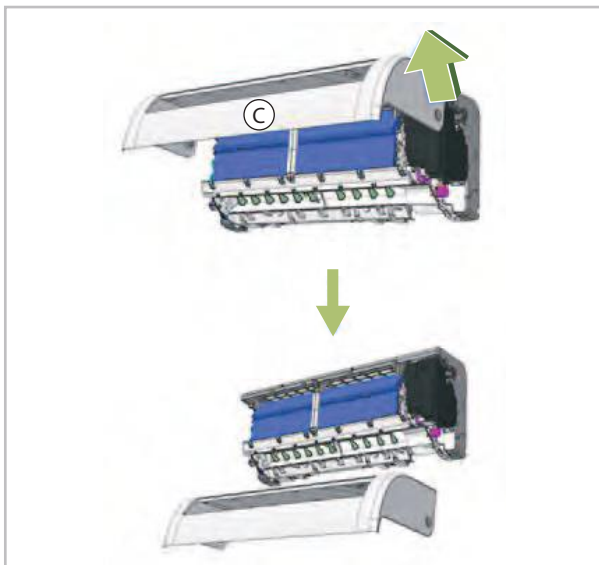

Fig. 46: Fold up the unit cover

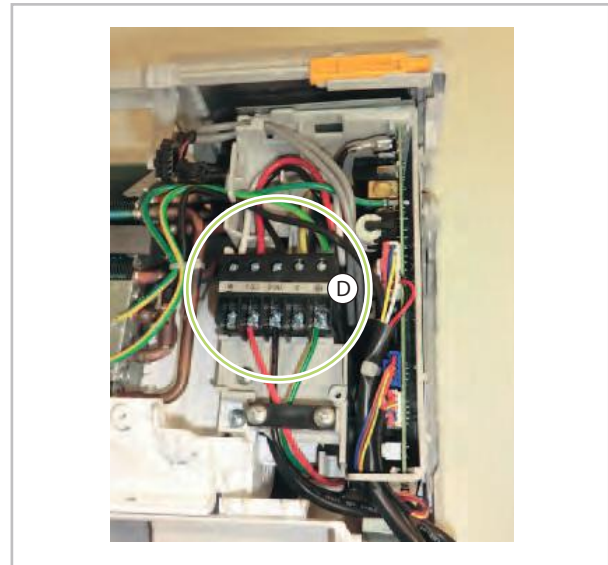

Fig. 47: Connecting the indoor unit

## 8.3 Connecting the outdoor unit

Proceed as follows to connect the line:

1. ➤ Remove the side-panel cover.
2. ➤ Choose a cable-section according to the relevant specifications.
3. ➤ Connect the lines as shown on the electrical connection diagram.
4. ➤ Fix the line in the strain relief and re-assemble the unit.

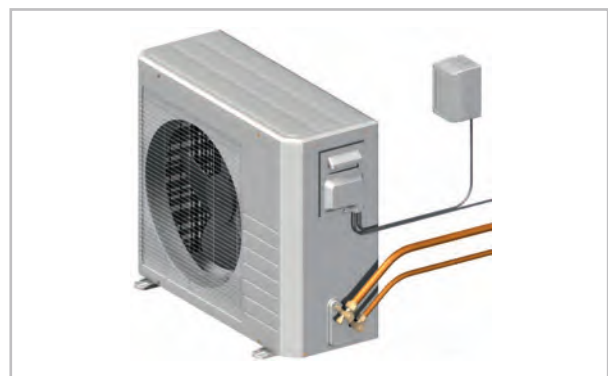

Fig. 48: Connecting the outdoor unit

## 8.4 Electrical wiring diagram

### Connection RVT 264-684 DC

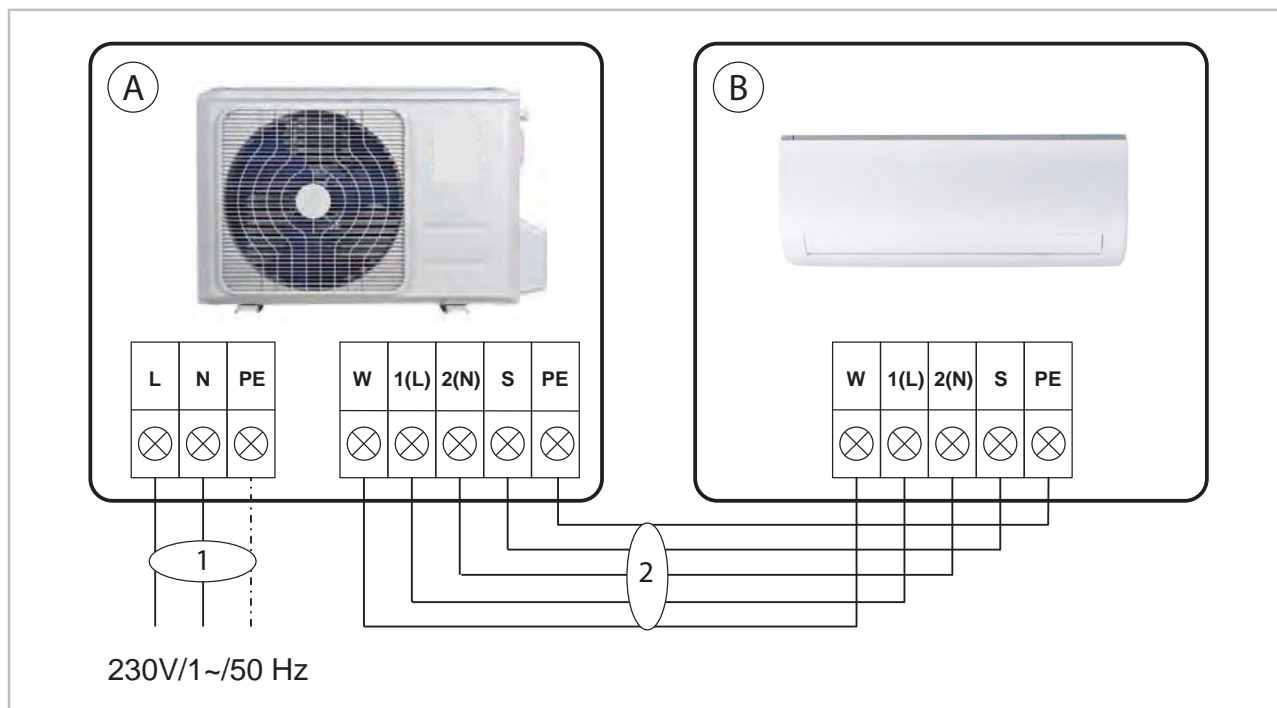

Fig. 49: Electrical wiring diagram

- A: Outdoor unit RVT 264-684 DC AT
- B: Indoor unit RVT 264-684 DC IT
- 1: Power supply
- 2: Communication line

# REMKO RVT-ARCTIC series

## Connection of optional condensate pump KP 6 / KP 8

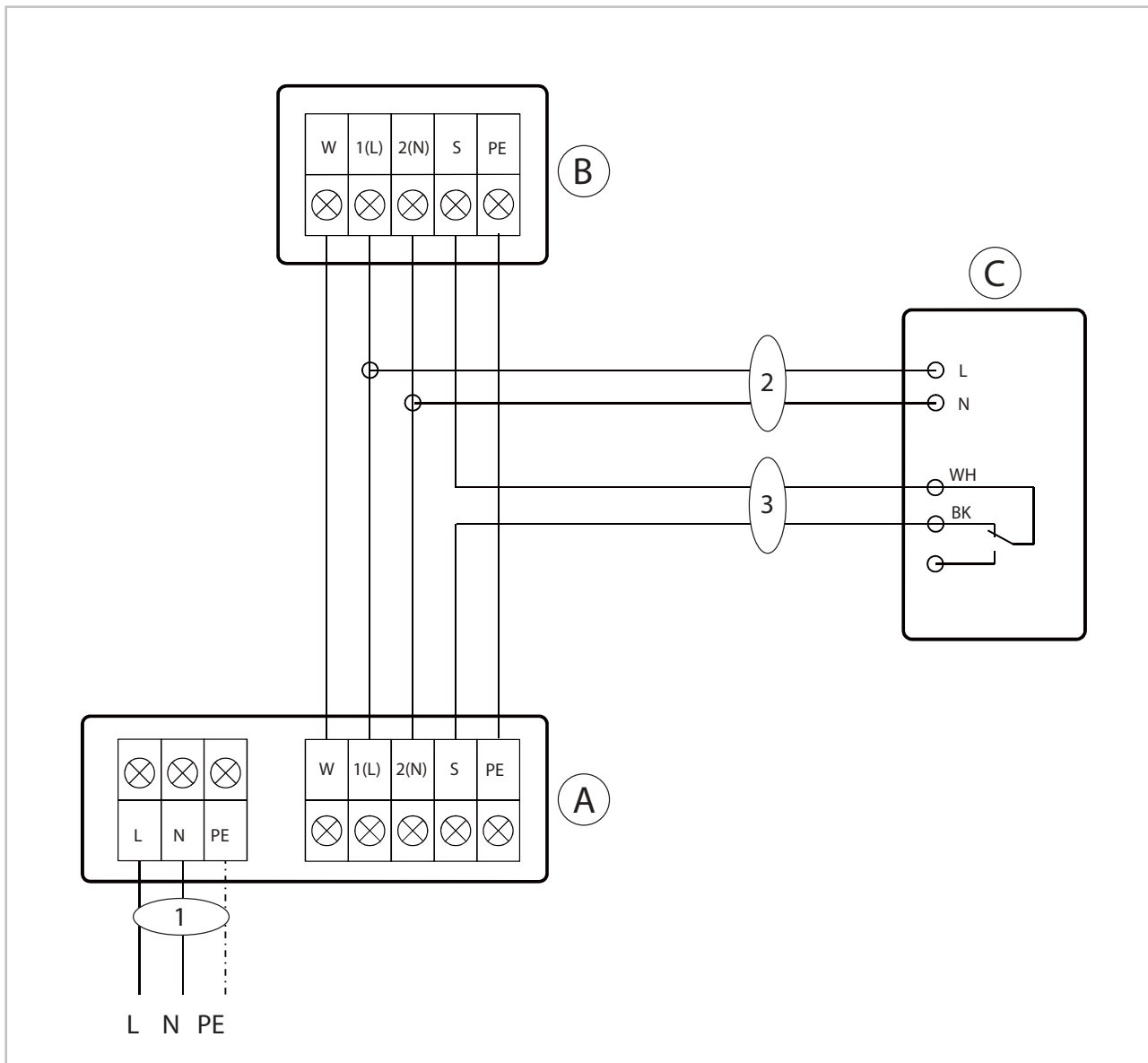

Fig. 50: Electrical wiring diagram

- A: Outdoor unit
- B: Indoor unit
- C: Condensate pump KP 6 / KP 8
- 1: Power supply

- 2: Condensate pump supply
- 3: Condensate pump fault contact
- BK: Black
- WH: white

## 8.5 Electrical drawings

### Indoor units RVT 264-684 DC IT

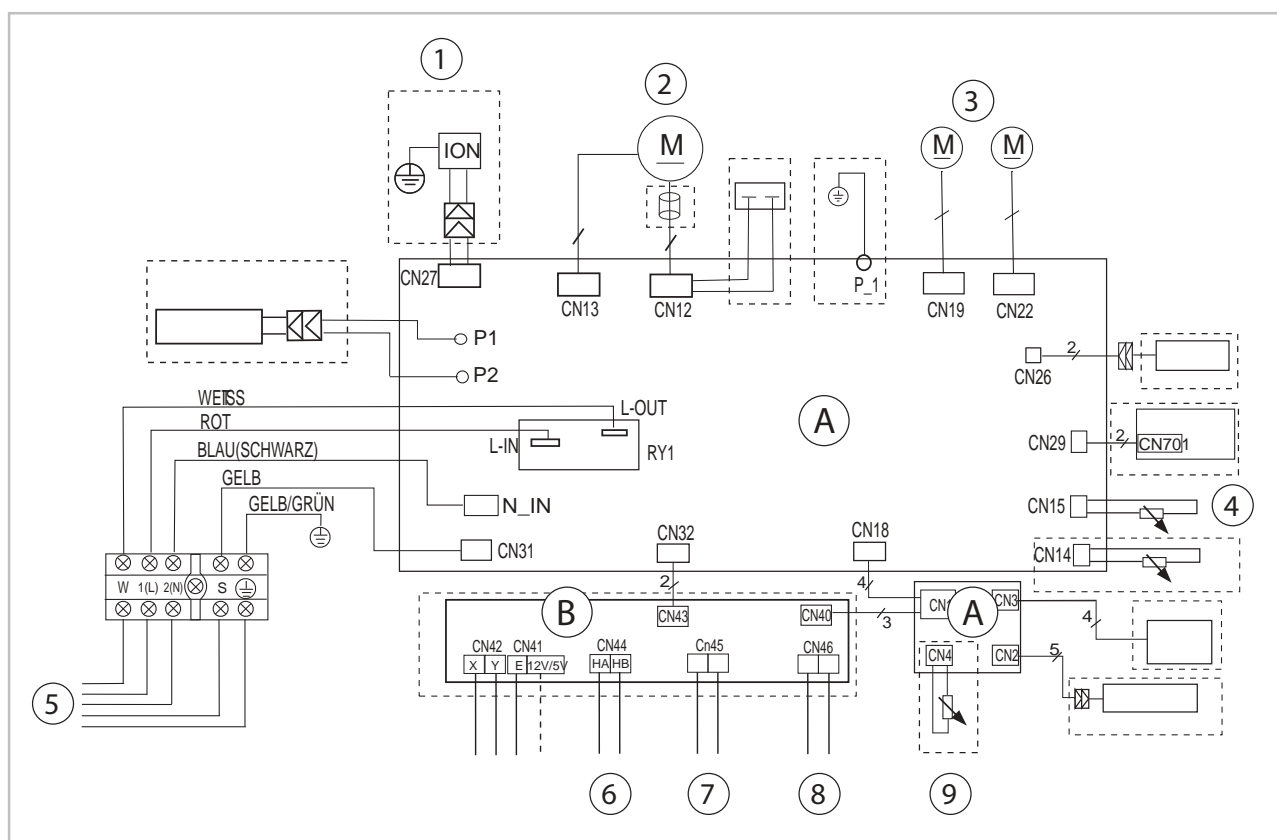

Fig. 51: Electrical drawings RVT 264-684 DC IT

- |                             |  |
|-----------------------------|--|
| A: Control board            | 4: Evaporator probe                      |
| B: Multifunction board      | 5: From the outdoor unit                 |
| C: Display board            | 6: Cable remote control connection KFB-W |
| 1: Ion generator (optional) | 7: Potential-free alarm contact          |
| 2: Fan motor                | 8: Contact for external on/off switching |
| 3: Fin motor                | 9: Ambient air probe                     |

# REMKO RVT-ARCTIC series

## Outdoor units RVT 264-354 DC AT

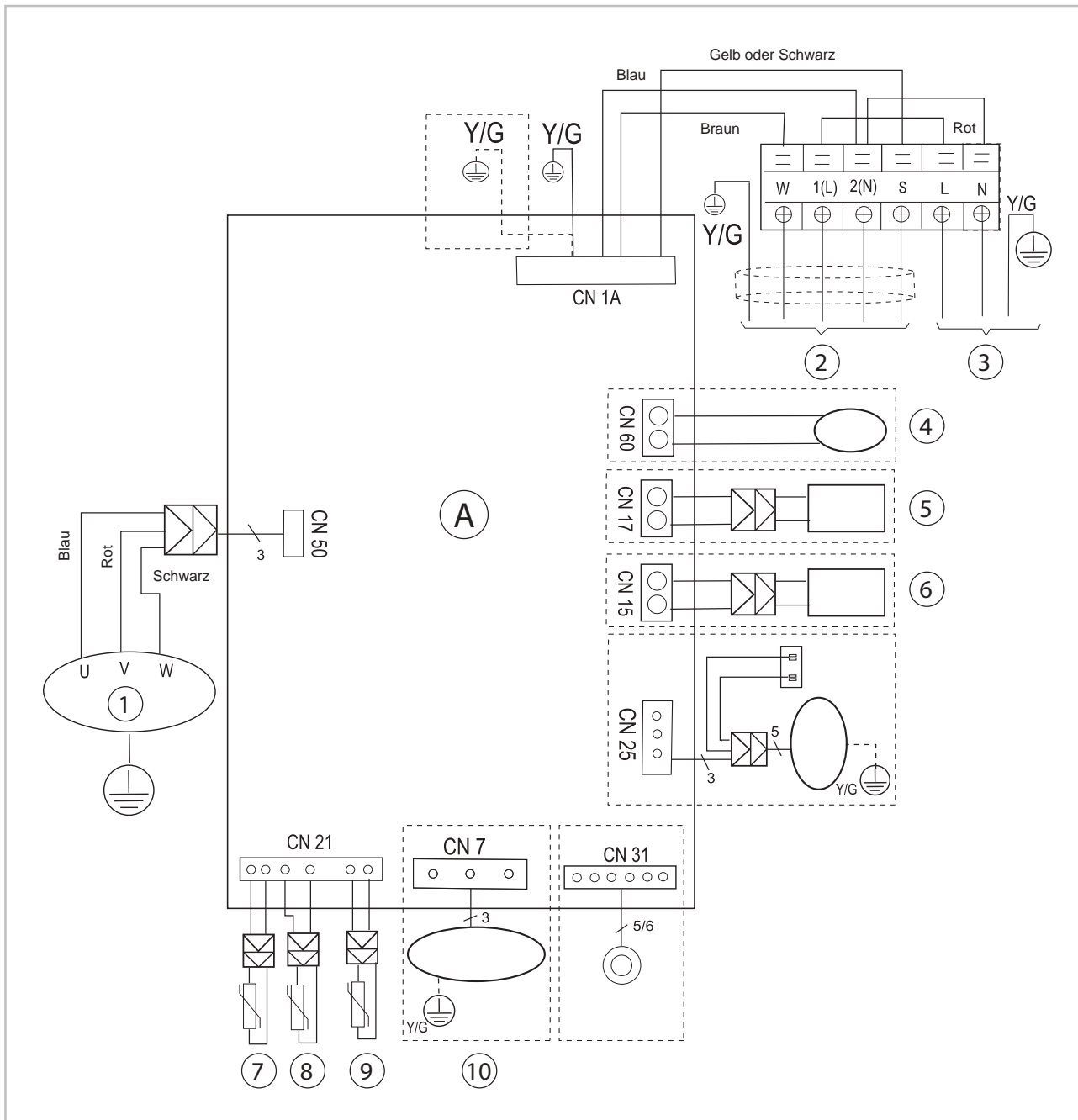

Fig. 52: Electrical drawings RVT 264-354 DC AT

- |                                   |                                       |
|-----------------------------------|---------------------------------------|
| A: Control board                  | 6: Condensate tray heating (optional) |
| 1: Compressor                     | 7: Heat gas probe                     |
| 2: Supply line to the indoor unit | 8: Condenser temperature probe        |
| 3: Power supply                   | 9: Condenser outlet temperature probe |
| 4: 4-way valve (optional)         | 10: Fan motor (optional)              |
| 5: Crankcase heating (optional)   |                                       |

## Outdoor units RVT 524-684 DC AT

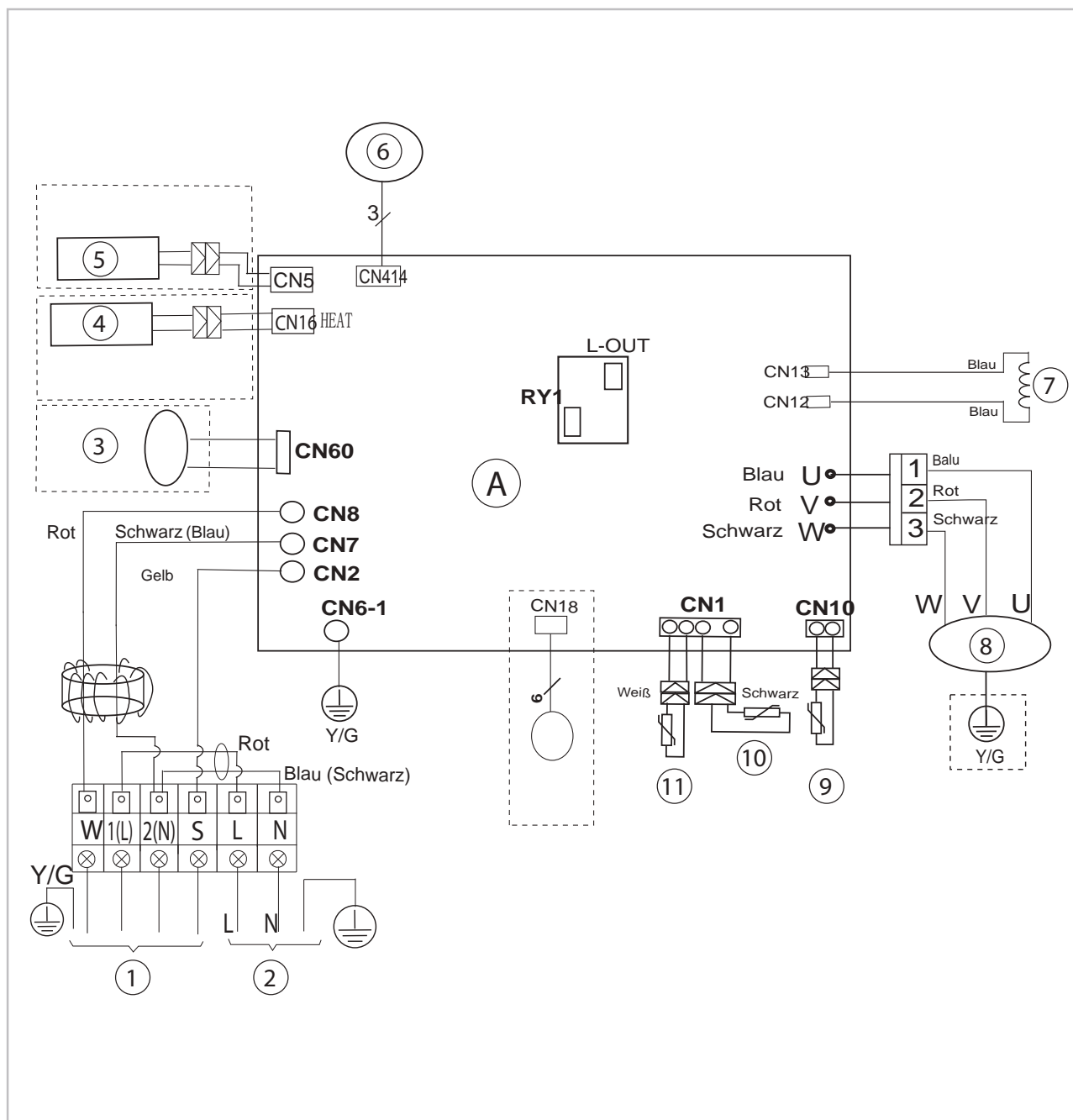

Fig. 53: Electrical drawings RVT 524-684 DC AT

- |                                       |  |
|---------------------------------------|--|
| A: Control board                      | 6: Fan motor (optional)                |
| 1: Supply line to the indoor unit     | 7: Transformer                         |
| 2: Power supply                       | 8: Compressor                          |
| 3: 4-way valve (optional)             | 9: Heat gas probe                      |
| 4: Crankcase heating (optional)       | 10: Condenser temperature probe        |
| 5: Condensate tray heating (optional) | 11: Condenser outlet temperature probe |

# REMKO RVT-ARCTIC series

## 8.6 Connection of a superordinate controller provided by the customer

Units of type RVT can be switched on and off by a superordinate controller.

In order to realise this function, it is necessary to insert the multifunction board provided (Fig. 54) in the unit and connect with the display and control board by means of a plug (s. Fig. 55 and Fig. 56).

The mount is fitted above the heat exchanger [B].

The multifunction board is slid into the mount previously fitted for this purpose.

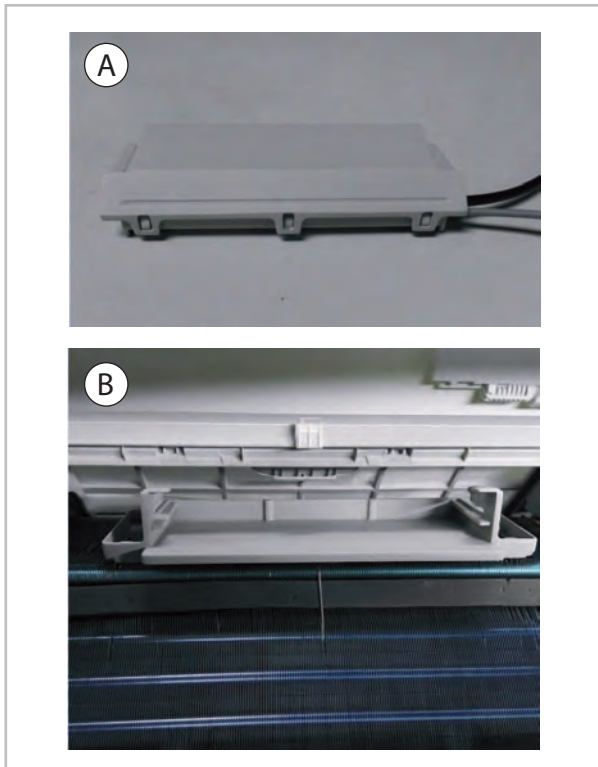

Fig. 54: Multifunction board

A: Multifunction board

B: Mount

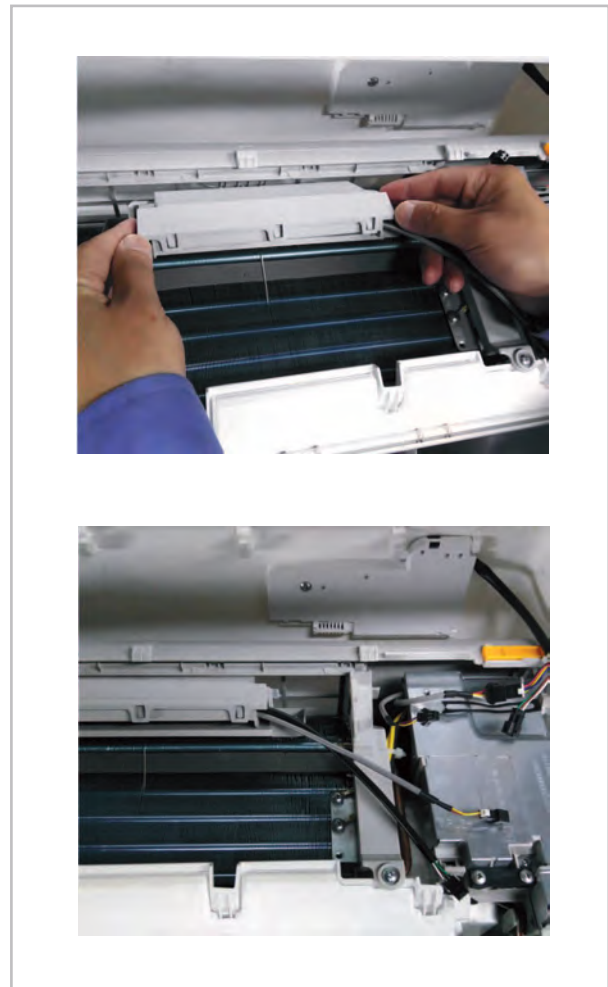

Fig. 55: Insert multifunction board in the unit



Fig. 56: Connect with the display and control board

The connection for the display board (black cable) / and for the control board (grey cable)



The multifunction board is equipped with a total of 3 terminals (see Fig. 57), with which the following functions can be realised:

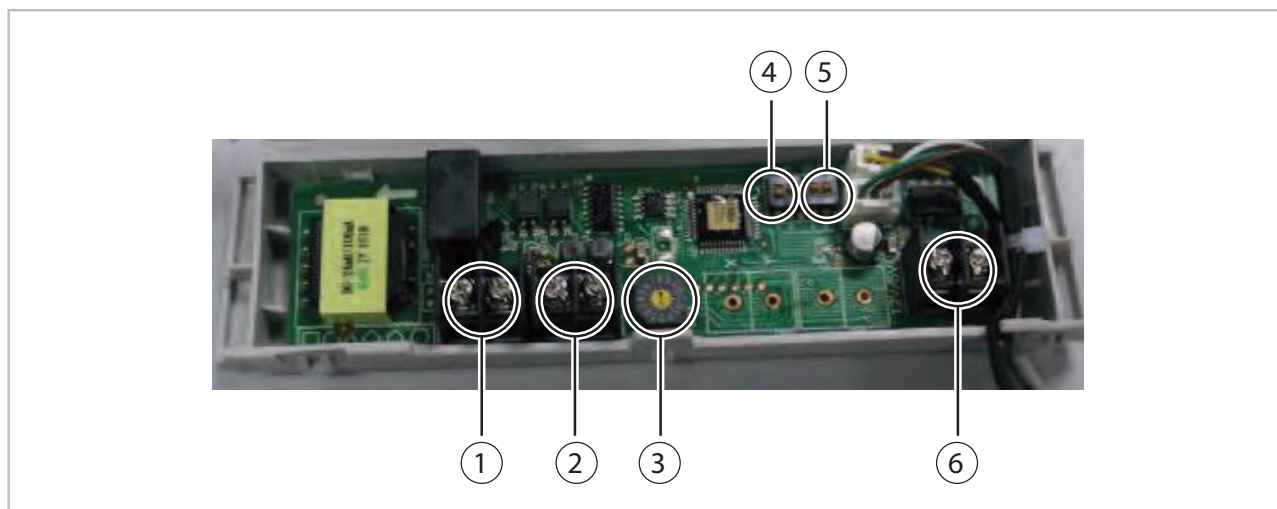

Fig. 57: Terminals

- 1: On/Off contact CN 46 / 2: KFB-W contact CN 44
- 3: Rotary switch addressing / 4: DIP switch F1
- 5: DIP switch F2 / 6: Alarm contact CN 45

#### ON/OFF1 terminals (CN 46):

Potential-free contact for switching the unit off externally. If this contact is opened (not bypassed), the system goes into standby. However, with the use of these two contacts switching on is still possible by infrared remote control. If this contact is closed (bypassed), the system reverts to the most recently used operating mode.

#### Connection of a cable remote control with week program (KFB-W):

Optionally, the cable remote control with week program KFB-W can be connected with the indoor unit.

The connection also takes place via the multifunction board supplied to the terminals CN 44 (s. Fig. 57).

The factory setting is programmed to address 0. The DIP switch F1 specifies the address range (e.g. both switches to OFF = address 0-15). The rotary switch ENC3 has 16 positions with which it stipulates the respective specific address (e.g. DIP switch F1 = both OFF and rotary switch ENC2 = 3 gives unit address 2). The customer is not required to perform any further programming here!

#### Alarm terminals (CN45):

Potential-free contact for the external transfer of an alarm. Function in factory setting:

- If the unit is switched off, the contact is closed
- If a malfunction is present on the unit, the contact is closed
- If no malfunction is present on the unit, the contact is open

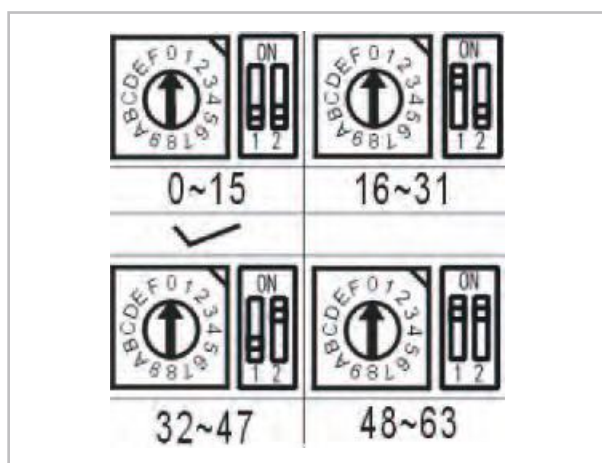

Fig. 58: DIP switch settings

#### CAUTION!

The relay behaviour can be changed via the DIP switch F2. Switch the DIP switch to ON, in order to use the NC contact as an NO contact.

# REMKO RVT-ARCTIC series

## Electrical wiring for optional KFB-R redundancy controller

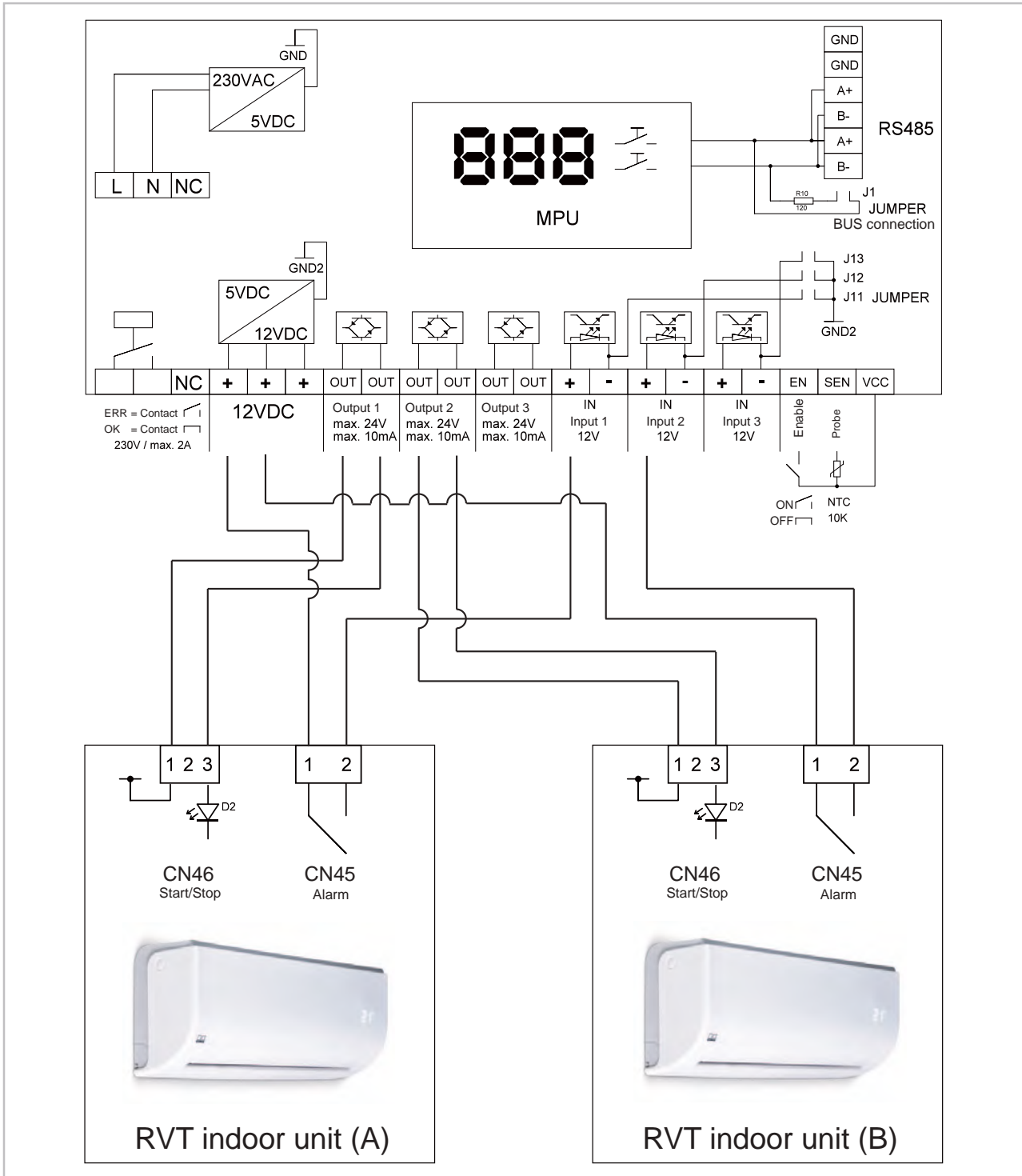

When establishing the connection between the unit series RVT 264-684 DC and the redundancy control KFB-R, the "InF" parameter of the redundancy control must be set to 1.

## 9 Before commissioning

After leak testing has been successfully completed, connect the vacuum pump via the pressure gauge station to the valve connections on the outdoor unit (see chapter "Leak testing") and create a vacuum.

Perform the following checks prior to putting the unit into operation for the first time and after any work on the cooling cycle. Record the results in the commissioning report:

- Check all refrigerant piping and valves for leak-tightness using leak detection spray or soapy water.
- Check the refrigerant piping and insulation for damage.
- Check the electrical connection between the indoor unit and the outdoor unit for correct polarity.
- Check that all fastenings, mountings, etc. are firm and at the correct level.

## 10 Commissioning

### ! NOTICE!

Commissioning should only be performed by specially trained personnel and documented after the certificate has been issued. Observe the operating manuals for the indoor unit and outdoor unit when commissioning the entire system.

Once all the components have been connected and tested, the system can be put into operation. A functional check should be performed to verify its correct function and identify any unusual operating behaviour prior to handing it over to the operator.

### ! NOTICE!

Check that the shut-off valves and valve caps are tight after carrying out any work on the cooling cycle. Use appropriate sealant products as necessary.

### Functional checks and test run

Check the following points:

- Leak-tightness of the refrigerant piping.
- Compressor and fan running smoothly.
- In cooling mode, cold air output by the indoor unit, and warm air output by the outdoor unit.
- Function test of the indoor unit and all program sequences.
- Check of the surface temperature of the suction pipe and that the vaporiser is not overheating. To measure the temperature, hold the thermometer to the suction pipe and subtract the boiling point temperature reading on the pressure gauge from the measured temperature.
- Record the measured temperatures in the commissioning report.

# REMKO RVT-ARCTIC series

## Function test of the cooling and heating modes

1. ▶ Remove the protective caps from the valves.
2. ▶ Start the commissioning procedure by briefly opening the shut-off valves on the outdoor unit until the pressure gauge indicates a pressure of approx. 2 bar.
3. ▶ Check all connections for leaks with leak detection spray and suitable leak detectors.
4. ▶ If no leaks are found, fully open the shut-off valves by turning them anti-clockwise using a spanner. If leaks are found, remedy the faulty connection. It is imperative that the vacuum creation and drying steps are repeated.
5. ▶ Activate the main circuit breaker or fuse (to be provided by the customer).
6. ▶ Press the test knob on the outdoor unit and wait until a frequency of min. 50 Hz is established.
7. ▶ Use the remote control to switch on the unit and select the cooling mode, maximum fan speed and lowest target temperature.
8. ▶ Check the overheating, outside, inside, outlet and vaporisation temperatures and record the measured values in the commissioning report. Check the correct function and settings of all regulation, control and safety devices.
9. ▶ Check the unit control system using the functions described in the chapter "Operation". Timer, temperature setting, fan speeds and switching to ventilation or dehumidification mode.
10. ▶ Check the correct function of the condensate drainage by pouring distilled water into the condensate tray. A bottle with a spout is recommended for pouring the water into the condensation tray.
11. ▶ Switch the indoor unit to heating mode.
12. ▶ During the test run, check the functionality of all of the previously described safety devices.
13. ▶ Record the measured values into the commissioning report and familiarise the operator with the system.
14. ▶ Remove the pressure gauge. Check that seals have been fitted in the sealing caps.
15. ▶ Re-install all disassembled parts.

# 11 Trouble-shooting, fault analysis and customer service

## 11.1 Störungsbeseitigung und Kundendienst

Die Geräte und Komponenten werden mit modernsten Fertigungsmethoden hergestellt und mehrfach auf fehlerfreie Funktion geprüft. Sollten dennoch Funktionsstörungen auftreten, so überprüfen Sie bitte die Funktion nach unterstehende Liste. Bei Anlagen mit Innengerät und Außenteil ist auch das Kapitel „Störungsbeseitigung und Kundendienst“ in beiden Bedienungsanleitungen zu beachten. Wenn alle Funktionskontrollen durchgeführt wurden und das Gerät immer noch nicht einwandfrei arbeitet, benachrichtigen Sie bitte Ihren Fachhändler!

### Funktionelle Störung

Störung	Mögliche Ursachen	Überprüfung	Abhilfe
Das Gerät läuft nicht an oder schaltet sich selbstständig ab	Stromausfall, Unterspannung, Netzsicherung defekt / Hauptschalter ausgeschaltet	Arbeiten alle anderen elektrischen Betriebsmittel?	Spannung überprüfen ggf. auf Wiedereinschalten warten
	Netzzuleitung beschädigt	Arbeiten alle anderen elektr. Betriebsmittel?	Instandsetzung durch einen Fachbetrieb
	Wartezeit nach dem Einschalten zu kurz	Sind nach dem Neustart ca. 5 Minuten vergangen?	Längere Wartezeiten einplanen
	Arbeitstemperatur unter- / überschritten	Arbeiten die Ventilatoren von IT und AT?	Temperaturbereiche von IT und AT beachten
	Überspannungen durch Gewitter	Gab es in letzter Zeit regionale Blitzeinschläge?	Abschaltung der Netzsicherung und erneuter Einschaltung. Überprüfung durch Fachbetrieb
	Störung der externen Kondensatpumpe	Hat die Pumpe eine Störabschaltung durchgeführt?	Pumpe überprüfen ggf. reinigen
Das Gerät reagiert nicht auf die Fernbedienung	Sendedistanz zu groß / Empfang gestört	Bei Tastendruck Signalton am Innengerät?	Distanz auf unter 6 m reduzieren und Standort wechseln
	Fernbedienung defekt	Arbeitet das Gerät im manuellen Betrieb?	Fernbedienung austauschen
	Empfangs- bzw. Sendeteil erfährt zu starke Sonneneinstrahlung	Ist die Funktion bei Beschattung gegeben?	Sendeteil bzw. Empfangsteil beschatten
	Elektromagnetische Felder stören die Übertragung	Ist die Funktion nach Ausschalten eventueller Störquellen gegeben?	Keine Signalübertragung bei gleichzeitigem Betrieb von Störquellen
	Taste der FB eingeklemmt / doppelte Tastenbedienung	Erscheint das "Sende"-Symbol in der Anzeige?	Taste entriegeln / nur eine Taste betätigen
	Batterien der Fernbedienung erschöpft	Sind frische Batterien eingesetzt? Ist die Anzeige unvollständig?	Frische Batterien einsetzen
Das Gerät arbeitet mit reduzierter oder ohne Kühlleistung	Filter ist verunreinigt / Lufteintritts-/Austrittsöffnung durch Fremdkörper blockiert	Sind die Filter gereinigt worden?	Filterreinigung durchführen

# REMKO RVT-ARCTIC series

Störung	Mögliche Ursachen	Überprüfung	Abhilfe
	Fenster und Türen geöffnet. Wärme-/ bzw. Kälte- last wurde erhöht	Gibt es eine bauliche / anwendungsmäßige Veränderung?	Fenster und Türen schließen / zusätzliche Anlagen montieren
	Kein Kühlbetrieb eingestellt	Ist das Kühlsymbol in der Anzeige aktiviert?	Einstellung des Gerätes korrigieren
	Lamellen des Außenteiles durch Fremdkörper blockiert	Arbeitet der Ventilator des Außenteils? Sind die Tauscherlamellen frei?	Ventilator oder Winterregelung überprüfen, Luftwiderstand reduzieren
	Undichtigkeit im Kältekreis	Ist eine Reifbildung an den Tauscherlamellen des Innengerätes sichtbar?	Instandsetzung durch Fachbetrieb
Kondensatwasseraustritt am Gerät	Ablaufrohr des Sammelbehälters verstopft / beschädigt	Ist der ungehinderte Kondensatablauf gewährleistet?	Reinigen des Ablaufrohres und des Sammelbehälters
	Externe Kondensatpumpe bzw. Schwimmer defekt	Ist die Auffangwanne voll Wasser und die Pumpe arbeitet nicht?	Pumpe vom Fachunternehmen ersetzen lassen
	Es befindet sich nicht abgelaufenes Kondensat in der Kondensatleitung	Ist die Kondensatleitung mit Gefälle verlegt und nicht verstopft?	Die Kondensatleitung mit Gefälle verlegen, bzw. reinigen
	Kondensat kann nicht abgeleitet werden	Sind die Kondensatleitungen frei und mit Gefälle verlegt? Arbeitet die Kondensatpumpe und der Schwimmerschalter?	Die Kondensatleitung mit Gefälle verlegen, bzw. reinigen. Ist der Schwimmerschalter bzw. die Kondensatpumpe defekt, diese ersetzen lassen

## NOTE

*If the outdoor unit makes noises at low outside temperatures, even although it is switched off, this is not a malfunction. This is the winding of the compressor being run briefly in order to heat up the oil within it and also to guarantee the viscosity at low ambient temperatures. If you do not use the unit in the winter then you can switch off the breaker. Switch it back on again at least 12 hours before the next time that the unit will be required!*

## Fehleranzeige am Innengerät

Anzeige	Fehlerbeschreibung
E0	EEPROM Fehler Innengerät
E1	Kommunikationsfehler zwischen Innengerät und Außenteil
E3	Drehzahlregelung Ventilator Innengerät außer Funktion
E4	Raumtemperatursensor T1 defekt
E5	Temperatursensor Verdampfer T2 defekt
F0	Überstromschutz
F1	Temperatursensor Lufteintritt Außenteil T4 defekt
F2	Temperatursensor Verflüssigerausritt T3 defekt
F3	Temperatursensor Heißgasleitung T5 defekt
F4	EEPROM Fehler Außenteil
F5	Drehzahlregelung Verflüssigerventilator außer Funktion
P0	Fehler Kompressoransteuerung
P1	Über- bzw. Unterspannungsfehler
P2	Überhitzungsschutz Kompressor (Heißgastemperatur zu hoch)
P4	Inverterregelung außer Funktion
EC	Keine Kühlleistung nach 30 Minuten
dF	Abtauung
CP	Keine externe Freigabe

Für die Fehlerbehebung siehe Troubleshooting auf den nachfolgenden Seiten.

## 11.2 Fehleranalyse Innengerät

Fehlercode:	E0 / F4
Grund:	Die Steuerplatine des Außenteils oder Innengeräts kann den Gerätespeicher (EEPROM) nicht lesen
Ursache:	<ul style="list-style-type: none"> <li>■ Installationsfehler</li> <li>■ Steuerplatinen Außenteil Innengerät defekt</li> </ul>

Spannung wegschalten, 2 Minuten später wieder zuschalten. Steht der Fehler noch an?

↓ YES

Tauschen Sie die Platinen des Außenteils und Innengerätes nacheinander aus, um den defekten EEPROM zu lokalisieren

# REMKO RVT-ARCTIC series

<b>Fehlercode:</b>	<b>E1</b>
<b>Grund:</b>	Das Innengerät empfängt innerhalb 110 Sekunden keine Signale vom Außenteil. Die Überprüfung erfolgt 4 mal hintereinander, dann erscheint Fehler E1.
<b>Ursache:</b>	<ul style="list-style-type: none"> <li>■ Elektrische Verbindung nicht korrekt ausgeführt</li> <li>■ Steuerplatine Außenteil oder Innengerät defekt</li> </ul>

Spannung wegschalten, 2 Minuten später wieder zuschalten. Steht der Fehler noch an?	
↓ YES	
Messen Sie die Spannung zwischen den Klemmen "S" und "N" am Außenteil. Schwankt der Wert zwischen -25V und 25V?	NO →
↓ YES	↓ YES
Elektrische Verbindungen im Außenteil prüfen. Sind diese in Ordnung?	Tauschen Sie die Steuerplatine des Innengerätes. Ist der Fehler behoben?
↓ YES	↓ NO
Ist der Transformator in Ordnung?	Tauschen Sie die Steuerplatine des Außenteils
↓ YES	NO →
Tauschen Sie die Steuerplatine des Außenteils. Ist der Fehler behoben?	Tauschen Sie den Transformator
↓ NO	
Tauschen Sie die Steuerplatine des Innengerätes	



Prüfen Sie den Transformator (dieser darf nicht mit einem Kondensator verbunden sein) mit einem Multimeter. Der Normalwert liegt bei ca. 0 Ohm. Sollte der Wert abweichen, tauschen Sie den Transformator aus.

Fig. 59: Messung des Transformators



<b>Fehlercode:</b>	<b>E3 / F5</b>
<b>Grund:</b>	Sollte die Ventilatorgeschwindigkeit des Innengerätes/Außenteils unter 300 U/min fallen, schaltet das Gerät ab und das Display zeigt Fehlercode E3 bzw. F5
<b>Ursache:</b>	<ul style="list-style-type: none"> <li>■ Elektrische Verbindung fehlerhaft</li> <li>■ Verdampferventilatorrad defekt</li> <li>■ Verdampferventilatormotor defekt</li> <li>■ Steuerplatine fehlerhaft</li> </ul>

Spannung wegschalten, 2 Minuten später wieder zuschalten. Steht der Fehler noch an?	NO →	Das Gerät arbeitet normal.	
↓YES			
Schalten Sie das Gerät stromlos und versuchen Sie das Ventilatorrad händisch zu drehen. Lässt sich dieses freihändig drehen?	NO →	Überprüfen Sie den Motor sowie das Ventilatorradlager und tauschen Sie die defekten Teile aus.	
↓YES			
Überprüfen Sie die elektrischen Verbindungen. Sind diese korrekt ausgeführt?	NO →	Stellen Sie die elektrische Verbindung korrekt hier	
↓YES			
Messen Sie die Spannung am entsprechenden Stecker der Steuerplatine (siehe Abschnitt <i>‘Vorgehensweise’</i> on page 58). Liegt die gemessene Spannung im Toleranzbereich?.	NO →	Tauschen Sie die Steuerplatine aus.	
↓YES			
Tauschen Sie den Ventilatormotor aus. Ist der Fehler behoben?	NO →		

# REMKO RVT-ARCTIC series

## Vorgehensweise

Gleichstromventilatormotor des Innengeräts (Steuerchip ist im Motor verbaut):

Schalten Sie die Spannung des Gerätes ein. Messen Sie im Standby Modus des Gerätes zwischen den Klemmen 1-3 und 4-3 des Verbindungssteckers. Überprüfen Sie die gemessenen Werte mit denen in der unten aufgeführten Tabelle. Weichen diese ab, besteht ein Problem der Steuerplatine und diese muss getauscht werden.

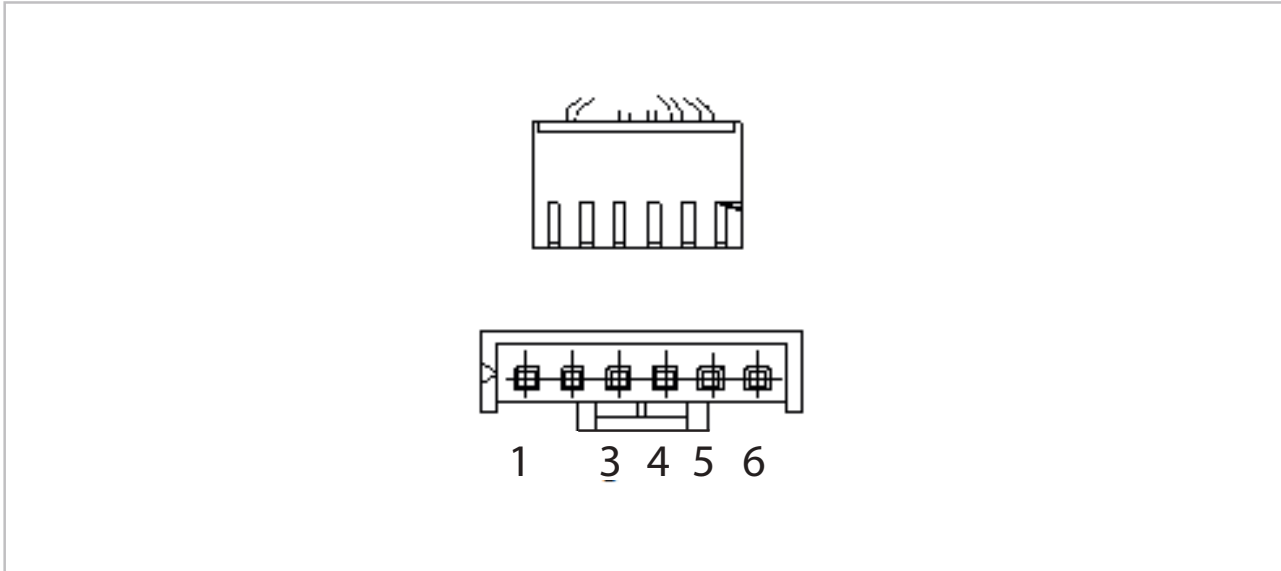

Fig. 60: Messung der Motoren

Klemme	Farbe	Spannung
1	Rot	280V~380V
2	---	---
3	Schwarz	0V
4	Weiß	14-17,5V
5	Gelb	0~5,6V
6	Blau	14-17,5V

Gleichstromventilatormotor des Außenteils (Steuerchip ist im Motor verbaut):

Messen Sie an den Widerstand zwischen den Klemmen 1-3 und 4-3. Dieser sollte annähernd identisch sein. Weicht der Widerstand stark ab, ist von einem Defekt des Motors auszugehen und dieser muss getauscht werden.

<b>Fehlercode:</b>	<b>EC</b>
<b>Grund:</b>	Der Verdampfersensor T2 misst beim Kompressorstart den aktuellen Wert und nimmt diesen als Referenzwert $T_{\text{Start}}$ . Sollte 8 Minuten nach Kompressorstart der Wert $T_{\text{Start}}$ nicht für mindestens 4 Sekunden um 2 °C gefallen sein, geht das System von einem Kältemittelmangel aus. Die Messung erfolgt insgesamt 3 mal bevor im Display der Fehlercode "EC" erscheint.
<b>Ursache:</b>	<ul style="list-style-type: none"> <li>■ Kältemittelmangel oder Kältekreislauf blockiert</li> <li>■ Verdampfersensor T2 defekt</li> <li>■ Steuerplatine Innengerät defekt</li> </ul>

Spannung wegschalten, 2 Minuten später wieder zuschalten. Steht der Fehler noch an?		
↓ YES		
Prüfen Sie, ob das Innengerät kalte Luft ausbläst.	→ YES	Überprüfen Sie die Position und Funktion des Verdampfersensors T2. Sitzt dieser korrekt und hat den korrekten Widerstand?
↓ NO		↓ YES
		Tauschen Sie die Steuerplatine des Innengeräts aus.
Überprüfen Sie den Kältekreislauf auf Undichtigkeiten. Undichtigkeit gefunden?	→ YES	Beheben Sie die Undichtigkeit und nehmen Sie das Gerät erneut in Betrieb.
↓ NO		
Überprüfen Sie den Kältekreislauf auf eventuelle Blockaden. Sind die Absperrhähne am Außenteil geöffnet?		

# REMKO RVT-ARCTIC series

<b>Fehlercode:</b>	<b>E4 / E5 / F1 / F2 / F3</b>
<b>Grund:</b>	Ist die Überprüfungsspannung der Sensoren niedriger als 0,06 V oder höher als 4,94 V, zeigt das Display den Fehlercode des entsprechenden Sensors an.
<b>Ursache:</b>	<ul style="list-style-type: none"> <li>■ Elektrische Verbindung fehlerhaft</li> <li>■ Defekt des Temperatursensors</li> <li>■ Steuerplatine defekt</li> </ul>

Überprüfen Sie das Verbindungskabel zwischen der Steuerplatine und dem Temperatursensor. Ist dieses in Ordnung und richtig eingesteckt?	<b>NO</b> →	Stellen Sie eine korrekte Verbindung her.
↓ <b>YES</b>		
Überprüfen Sie den Sensor auf korrekten Widerstand in Abhängigkeit zur Temperatur (siehe Widerstandstabelle)	<b>NO</b> →	Tauschen Sie den Sensor aus.
↓ <b>YES</b>		
Tauschen Sie die entsprechende Steuerplatine aus.		

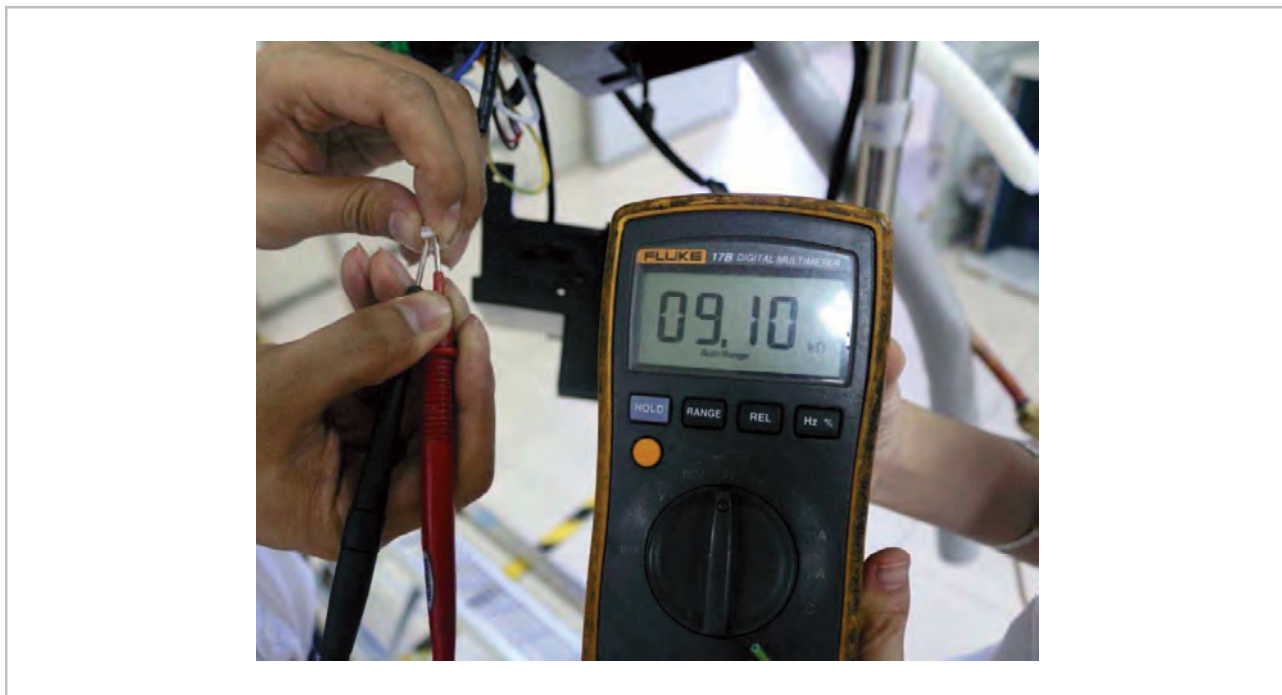

Fig. 61: Überprüfung der Sensoren

<b>Fehlercode:</b>	<b>F0</b>
<b>Grund:</b>	Sicherheitsabschaltung aufgrund zu hoher Stromaufnahme einzelner Gerätekomponenten
<b>Ursache:</b>	<ul style="list-style-type: none"> <li>■ Fehlerhafte Netzzuleitung</li> <li>■ Kältekreislauf blockiert</li> <li>■ Fehlerhafte Steuerplatine</li> <li>■ Elektrische Verbindungen fehlerhaft</li> <li>■ Kompressor defekt</li> </ul>

Überprüfen Sie die Versorgungsspannung. Ist diese korrekt?	<b>NO</b> →	Schalten Sie das Gerät aus und sorgen Sie für korrekte Versorgungsspannung.
↓YES		
Überprüfen Sie den Kältekreislauf auf eventuelle Blockaden. Ist der Kältekreislauf in Ordnung?	<b>NO</b> →	Entfernen Sie die Blockade (Absperrhähne geöffnet?)
↓YES		
Überprüfen Sie die Wicklungswiderstände des Kompressors. Sind diese in Ordnung?	<b>NO</b> →	Tauschen Sie den Kompressor.
↓YES		
Überprüfen Sie die elektrischen Verbindungen. Sind diese korrekt ausgeführt?	<b>NO</b> →	Erneuern bzw. korrigieren Sie die elektrischen Verbindungen.
↓YES		
Arbeitet der Transformator fehlerfrei? (siehe ↪ on page 56)	<b>NO</b> →	Tauschen Sie den Transformator oder die Steuerplatine des Außenteils aus.
↓YES		
Tauschen Sie das Außenteil.		

# REMKO RVT-ARCTIC series

<b>Fehlercode:</b>	<b>P0</b>
<b>Grund:</b>	Ist die Spannungsversorgung zur Kompressorregelung fehlerhaft zeigt das Display den Fehlercode "P0" und das Gerät schaltet sich aus
<b>Ursache:</b>	<ul style="list-style-type: none"> <li>■ Elektrische Verbindung fehlerhaft</li> <li>■ Fehlerhafte Steuerplatine</li> <li>■ Verflüssigerventilatormotor defekt oder blockiert</li> <li>■ Kompressor defekt</li> </ul>

Überprüfen Sie die Verbindungskabel zwischen Steuerplatine und Kompressor? Sind diese fehlerhaft?	<b>YES</b> →	Stellen Sie eine korrekte Verbindung zwischen Steuerplatine und Kompressor her.
↓ <b>NO</b>		
Überprüfen Sie die Inverterregelung (siehe Abschnitt ↗ 'Inverterregelung kontrollieren' on page 62). Fehler behoben?	<b>NO</b> →	Tauschen Sie die Steuerplatine aus.
↓ <b>YES</b>		
Überprüfen Sie den Verflüssigerventilatormotor. Arbeitet dieser korrekt?	<b>NO</b> →	Siehe Troubleshooting Fehler F5
↓ <b>YES</b>		
Überprüfen Sie die Wicklungswiderstände des Kompressors. Sind diese in Ordnung?	<b>NO</b> →	Tauschen Sie den Kompressor.
↓ <b>YES</b>		
Tauschen Sie die Steuerplatine des Außenteils aus.		

## Inverterregelung kontrollieren

Schalten Sie das Gerät spannungslos. Warten Sie bis die Kondensatoren komplett entladen sind und klemmen Sie den Kompressor an der Steuerplatine ab.

Überprüfen Sie die Widerstände an den Ausgängen der Steuerplatine mit Hilfe eines digitalen Voltmeters wie folgt:

Voltmeter		Normaler Widerstand			
(+) Rot	(-) Schwarz	RVT 264 DC	RVT 354 DC	RVT 524 DC	RVT 684 DC
U	N	2,35Ω (20°C/68°F)	1,57Ω (20°C/68°F)	1,75Ω (20°C/68°F)	0,75Ω (20°C/68°F)
V					
W					
(+) Rot					

<b>Fehlercode:</b>	<b>P1</b>	
<b>Grund:</b>	Über- oder Unterspannungsschutz hat angesprochen	
<b>Ursache:</b>	<ul style="list-style-type: none"> <li>■ Fehlerhafte Versorgungsspannung</li> <li>■ Kältemittelmangel oder Kältekreislauf blockiert</li> <li>■ Fehlerhafte Steuerplatine</li> </ul>	
Überprüfen Sie die Netzzuleitung. Ist die Versorgungsspannung korrekt?	<b>NO</b> →	Schalten Sie das Gerät aus und lassen Sie die Netzzuleitung überprüfen/korrigieren.
↓YES		
Überprüfen Sie die elektrischen Verbindungen. Sind diese in Ordnung?	<b>NO</b> →	Erneuern Sie die elektrischen Verbindungen.
↓YES		
Schalten Sie die Spannung ein und versetzen Sie das Gerät in den Standby Modus. Messen Sie die Spannung auf der Platine an den Kontakten "P" und "N". Diese sollte ca. 310V, 340V oder 380V DC betragen. Starten Sie nun das Gerät. Die Spannung zwischen "P" und "N" sollte nun zwischen 220-400V betragen. Liegt die korrekte Spannung an?	<b>NO</b> →	Tauschen Sie die Steuerplatine aus.
↓YES		
Kontrollieren Sie den Transformator. Liegt ein Defekt vor?	<b>NO</b> →	Tauschen Sie die Steuerplatine aus.
↓YES		
Tauschen Sie den Transformator aus.		

# REMKO RVT-ARCTIC series

<b>Fehlercode:</b>	<b>P2 (bei Geräten mit Thermokontakt)</b>
<b>Grund:</b>	Liegt die Überprüfungsspannung des Thermokontaktes nicht bei 5V zeigt das Display Fehlermeldung "P2"
<b>Ursache:</b>	<ul style="list-style-type: none"> <li>■ Fehlerhafte Versorgungsspannung</li> <li>■ Kältemittelmangel oder Kältekreislauf blockiert</li> <li>■ Fehlerhafte Steuerplatine</li> </ul>

Überprüfen Sie die Luftvolumenströme des Außenteils sowie des Innengerätes. Sind diese blockiert bzw. verschmutzt?	<b>YES</b> →	Reinigen Sie die Filter bzw. die Wärmetauscher und sorgen Sie für ausreichenden Luftvolumenstrom.	
<b>↓NO</b>			
Schalten Sie das Gerät spannungsfrei und nach 10 Minuten wieder ein. Läuft das Gerät an?			
<b>↓YES</b>			
Überprüfen Sie die Temperatur des Kompressors. Ist dieser heiß gelaufen?	<b>NO</b> →	Überprüfen Sie den Thermokontakt. Ist dieser korrekt angeschlossen?	
		<b>↓YES</b>	<b>↓NO</b>
		Messen Sie den Widerstand des Thermokontaktes. Ist dieser 0?	Schließen Sie diesen korrekt an.
<b>↓YES</b>		<b>↓YES</b>	<b>NO</b> →
Überprüfen Sie den Kältekreislauf. Ist dieser in Ordnung?	<b>YES</b> →	Tauschen Sie die Steuerplatine des Außenteiles.	Tauschen Sie den Thermokontakt aus.



<b>Fehlercode:</b>	<b>P4</b>
<b>Grund:</b>	Sicherheitsabschaltung Inverterregelung. Systeminterne Überwachung angesprochen (z.B. Kommunikationsproblem zwischen Platine und Kompressor, Drehzahl Kompressor nicht in Ordnung)
<b>Ursache:</b>	<ul style="list-style-type: none"> <li>■ Fehlerhafte elektrische Verbindungen</li> <li>■ Inverterregelung auf Platine defekt</li> <li>■ Verflüssigerventilatormotor defekt</li> <li>■ Kompressor defekt</li> <li>■ Steuerplatine defekt</li> </ul>

Überprüfen Sie die elektrische Verbindung zwischen der Steuerplatine und dem Kompressor. Sind diese korrekt ausgeführt?	<b>YES</b> →	Stellen Sie eine korrekte Verbindung her.
↓ <b>NO</b>		
Überprüfen Sie die Inverterregelung. Ist diese funktionstüchtig?	<b>NO</b> →	Tauschen Sie die Steuerplatine aus.
↓ <b>YES</b>		
Überprüfen Sie den Verflüssigerventilatormotor. Ist dieser in Ordnung?	<b>NO</b> →	Folgen Sie den Anweisungen aus Troubleshooting Fehler F5
↓ <b>YES</b>		
Überprüfen Sie die Wicklungswiderstände des Kompressors. Sind diese in Ordnung?	<b>NO</b> →	Tauschen Sie den Kompressor aus
↓ <b>YES</b>		
Tauschen Sie die Steuerplatine des Außenteils.		

### Einzelne Komponenten prüfen. Überprüfung der Temperatursensoren

Klemmen Sie den Temperatursensor von der Steuerplatine ab, messen Sie den Widerstand an den Kontakten des Steckers.

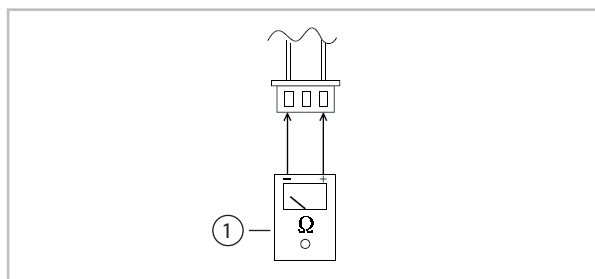

1: Multimeter

<b>Fehlercode:</b>	<b>dF</b>
<b>Grund:</b>	Das Gerät befindet sich im Heizbetrieb und das Außenteil wird abgetaut. Nach der Abtau-phase schaltet das Innengerät automatisch in den letzten Betriebsmodus zurück.

# REMKO RVT-ARCTIC series

## Widerstandswerte der Sensoren T1, T2, T3 und T4

°C	°F	K Ohm	°C	°F	K Ohm	°C	°F	K Ohm	°C	°F	K Ohm
-20	-4	115.266	20	68	12.6431	60	140	2.35774	100	212	0.62973
-19	-2	108.146	21	70	12.0561	61	142	2.27249	101	214	0.61148
-18	0	101.517	22	72	11.5	62	144	2.19073	102	216	0.59386
-17	1	96.3423	23	73	10.9731	63	145	2.11241	103	217	0.57683
-16	3	89.5865	24	75	10.4736	64	147	2.03732	104	219	0.56038
-15	5	84.219	25	77	10	65	149	1.96532	105	221	0.54448
-14	7	79.311	26	79	9.55074	66	151	1.89627	106	223	0.52912
-13	9	74.536	27	81	9.12445	67	153	1.83003	107	225	0.51426
-12	10	70.1698	28	82	8.71983	68	154	1.76647	108	226	0.49989
-11	12	66.0898	29	84	8.33566	69	156	1.70547	109	228	0.486
-10	14	62.2756	30	86	7.97078	70	158	1.64691	110	230	0.47256
-9	16	58.7079	31	88	7.62411	71	160	1.59068	111	232	0.45957
-8	18	56.3694	32	90	7.29464	72	162	1.53668	112	234	0.44699
-7	19	52.2438	33	91	6.98142	73	163	1.48481	113	235	0.43482
-6	21	49.3161	34	93	6.68355	74	165	1.43498	114	237	0.42304
-5	23	46.5725	35	95	6.40021	75	167	1.38703	115	239	0.41164
-4	25	44	36	97	6.13059	76	169	1.34105	116	241	0.4006
-3	27	41.5878	37	99	5.87359	77	171	1.29078	117	243	0.38991
-2	28	39.8239	38	100	5.62961	78	172	1.25423	118	244	0.37956
-1	30	37.1988	39	102	5.39689	79	174	1.2133	119	246	0.36954
0	32	35.2024	40	104	5.17519	80	176	1.17393	120	248	0.35982
1	34	33.3269	41	106	4.96392	81	178	1.13604	121	250	0.35042
2	36	31.5635	42	108	4.76253	82	180	1.09958	122	252	0.3413
3	37	29.9058	43	109	4.5705	83	181	1.06448	123	253	0.33246
4	39	28.3459	44	111	4.38736	84	183	1.03069	124	255	0.3239
5	41	26.8778	45	113	4.21263	85	185	0.99815	125	257	0.31559
6	43	25.4954	46	115	4.04589	86	187	0.96681	126	259	0.30754
7	45	24.1932	47	117	3.88673	87	189	0.93662	127	261	0.29974
8	46	22.5662	48	118	3.73476	88	190	0.90753	128	262	0.29216
9	48	21.8094	49	120	3.58962	89	192	0.8795	129	264	0.28482
10	50	20.7184	50	122	3.45097	90	194	0.85248	130	266	0.2777
11	52	19.6891	51	124	3.31847	91	196	0.82643	131	268	0.27078
12	54	18.7177	52	126	3.19183	92	198	0.80132	132	270	0.26408
13	55	17.8005	53	127	3.07075	93	199	0.77709	133	271	0.25757
14	57	16.9341	54	129	2.95896	94	201	0.75373	134	273	0.25125
15	59	16.1156	55	131	2.84421	95	203	0.73119	135	275	0.24512
16	61	15.3418	56	133	2.73823	96	205	0.70944	136	277	0.23916
17	63	14.6181	57	135	2.63682	97	207	0.68844	137	279	0.23338
18	64	13.918	58	136	2.53973	98	208	0.66818	138	280	0.22776
19	66	13.2631	59	138	2.44677	99	210	0.64862	139	282	0.22231

### Widerstandswerte des Sensors T5

°C	°F	K Ohm	°C	°F	K Ohm	°C	°F	K Ohm	°C	°F	K Ohm
-20	-4	542.7	20	68	68.66	60	140	13.59	100	212	3.702
-19	-2	511.9	21	70	65.62	61	142	13.11	101	214	3.595
-18	0	483	22	72	62.73	62	144	12.65	102	216	3.492
-17	1	455.9	23	73	59.98	63	145	12.21	103	217	3.392
-16	3	430.5	24	75	57.37	64	147	11.79	104	219	3.296
-15	5	406.7	25	77	54.89	65	149	11.38	105	221	3.203
-14	7	384.3	26	79	52.53	66	151	10.99	106	223	3.113
-13	9	363.3	27	81	50.28	67	153	10.61	107	225	3.025
-12	10	343.6	28	82	48.14	68	154	10.25	108	226	2.941
-11	12	325.1	29	84	46.11	69	156	9.902	109	228	2.86
-10	14	307.7	30	86	44.17	70	158	9.569	110	230	2.781
-9	16	291.3	31	88	42.33	71	160	9.248	111	232	2.704
-8	18	275.9	32	90	40.57	72	162	8.94	112	234	2.63
-7	19	261.4	33	91	38.89	73	163	8.643	113	235	2.559
-6	21	247.8	34	93	37.3	74	165	8.358	114	237	2.489
-5	23	234.9	35	95	35.78	75	167	8.084	115	239	2.422
-4	25	222.8	36	97	34.32	76	169	7.82	116	241	2.357
-3	27	211.4	37	99	32.94	77	171	7.566	117	243	2.294
-2	28	200.7	38	100	31.62	78	172	7.321	118	244	2.233
-1	30	190.5	39	102	30.36	79	174	7.086	119	246	2.174
0	32	180.9	40	104	29.15	80	176	6.859	120	248	2.117
1	34	171.9	41	106	28	81	178	6.641	121	250	2.061
2	36	163.3	42	108	26.9	82	180	6.43	122	252	2.007
3	37	155.2	43	109	25.86	83	181	6.228	123	253	1.955
4	39	147.6	44	111	24.85	84	183	6.033	124	255	1.905
5	41	140.4	45	113	23.89	85	185	5.844	125	257	1.856
6	43	133.5	46	115	22.89	86	187	5.663	126	259	1.808
7	45	127.1	47	117	22.1	87	189	5.488	127	261	1.762
8	46	121	48	118	21.26	88	190	5.32	128	262	1.717
9	48	115.2	49	120	20.46	89	192	5.157	129	264	1.674
10	50	109.8	50	122	19.69	90	194	5	130	266	1.632
11	52	104.6	51	124	18.96	91	196	4.849			
12	54	99.69	52	126	18.26	92	198	4.703			
13	55	95.05	53	127	17.58	93	199	4.562			
14	57	90.66	54	129	16.94	94	201	4.426			
15	59	86.49	55	131	16.32	95	203	4.294			
16	61	82.54	56	133	15.73	96	205	4.167			
17	63	78.79	57	135	15.16	97	207	4.045			
18	64	75.24	58	136	14.62	98	208	3.927			
19	66	71.86	59	138	14.09	99	210	3.812			

# REMKO RVT-ARCTIC series

## 12 Care and maintenance

Regular care and observation of some basic points will ensure trouble-free operation and a long service life.

### DANGER!

Prior to performing any work, ensure the equipment is disconnected from the voltage supply and secured to prevent accidental switch-on!

### Care

- Ensure the unit is protected against dirt, mould and other deposits.
- Only clean the unit using a damp cloth. Do not use any caustic, abrasive or solvent-based cleaning products. Do not use a jet of water.
- Clean the fins on the unit prior to long shut-down periods.

### Maintenance

- It is recommended that you take out a maintenance contract with an annual service from an appropriate specialist firm.



*This enables you to ensure the operational reliability of the plant at all times!*

### NOTICE!

Statutory regulations require an annual leak test for the cooling cycle dependant on the refrigerant quantity. Inspection and documentation of the work performed is to be carried out by specialist technicians.

Type of task Checks/maintenance/inspection	Commis- sioning	Monthly	Every 6 months	Yearly
General	●			●
Check voltage and current	●			●
Check function of compressor/fans	●			●
Dirt on condenser/evaporator	●	●		
Check refrigerant fill quantity	●		●	
Check condensate drainage	●		●	
Check insulation	●			●
Check moving parts	●			●
Sealing test for cooling cycle	●			● <sup>1)</sup>

<sup>1)</sup> see note

### Cleaning the housing

1. ➤ Disconnect the power supply to the unit.
2. ➤ Open and fold the air inlet grill on the front side upwards.
3. ➤ Clean the grill and cover with a soft, damp cloth.
4. ➤ Switch the power supply back on.

### Cleaning the air filter

Clean the air filter at intervals of no more than 2 weeks. Reduce this interval if the air is especially dirty.

The air filters are on the top side of the unit. It is not necessary to open the unit in order to remove the air filter.

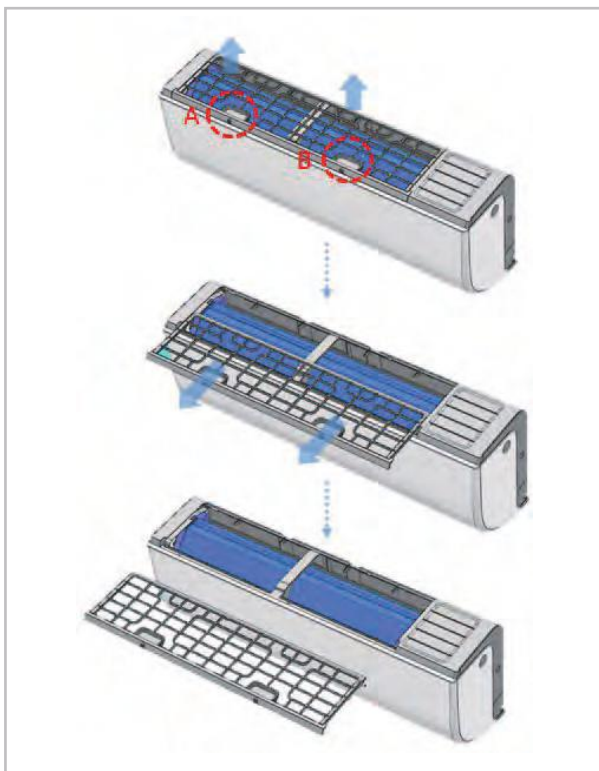

1. ➤ Draw the filter forwards with the aid of the recessed grips [A+B].

2. ➤ Clean the filter with a commercially available vacuum cleaner. To do so, turn the dirty side so it is facing upwards.



3. ➤ Dirt can also be removed by carefully cleaning with lukewarm water and mild cleaning agents. The dirty side should be face down.



4. ➤ If water is used, let the filter dry out properly in the air before fitting it back into the unit.
5. ➤ Carefully insert the filter. Ensure that it locates correctly.

### Cleaning the condensate pump (accessories)

The indoor unit may contain an optional integrated or separate condensate pump, which pumps out any accumulated condensate into higher positioned drains.

Observe the care and maintenance instructions in the separate operating manual.

# REMKO RVT-ARCTIC series

## 13 Shutdown

### Temporary shutdown

1. ▶ Let the indoor unit run for 2 to 3 hours in recirculation mode, or in cooling mode at maximum temperature, to extract any residual humidity from the unit.
2. ▶ Shut down the system using the remote control.
3. ▶ Switch off the electrical power supply to the unit.
4. ▶ Cover the unit as far as possible with plastic foil in order to protect it from the influences of weather.

### Permanent shutdown

Ensure that units and components are disposed of in accordance with local regulations, e.g. through authorised disposal and recycling specialists or at collection points.

REMKO GmbH & Co. KG or your contractual partner will be pleased to provide a list of certified firms in your area.

## 14 Exploded view and spare parts lists

### 14.1 Exploded view - Indoor unit RVT 264-684 DC IT

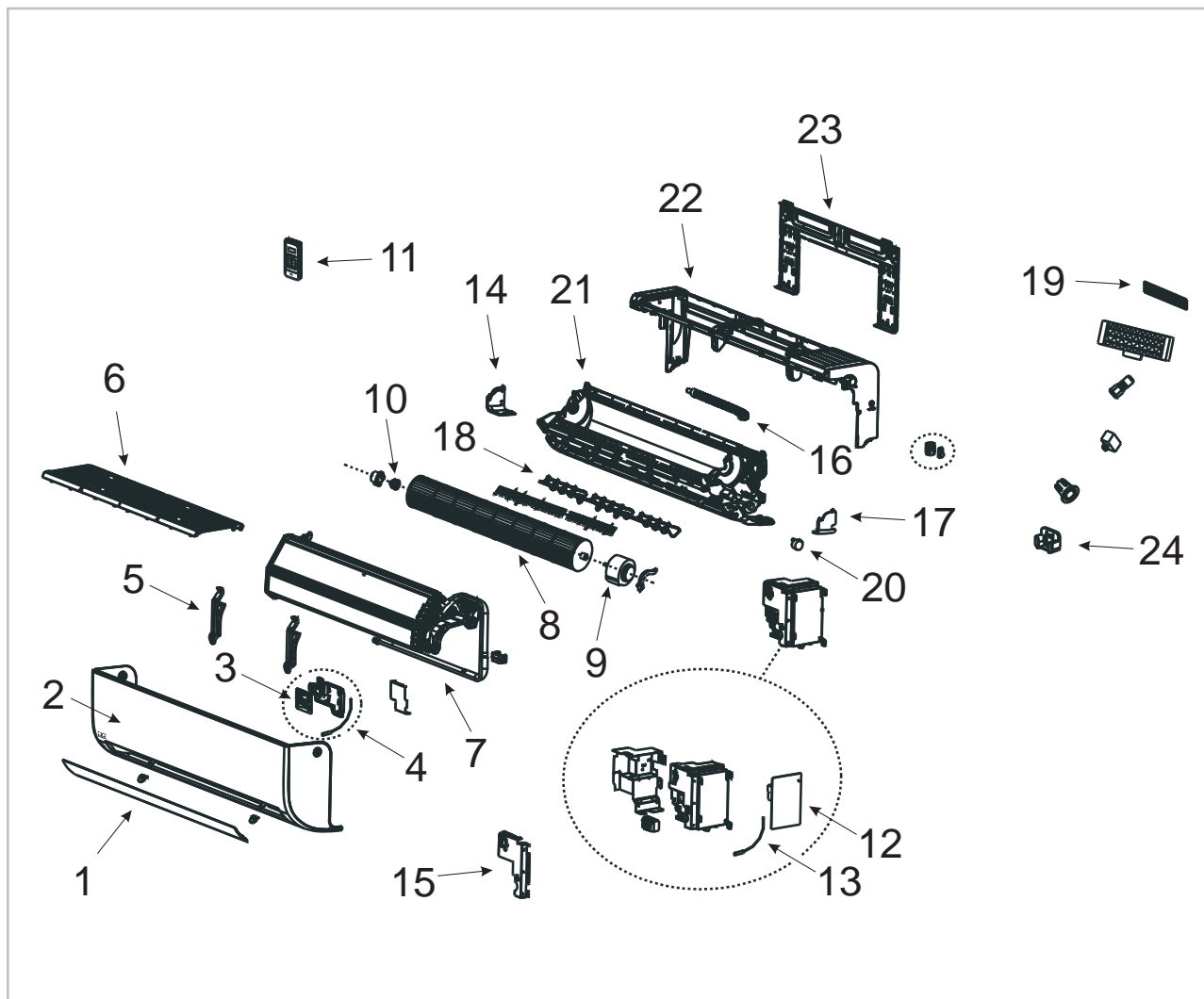

Fig. 62: Exploded view of the unit RVT 264-684 DC IT

We reserve the right to modify the dimensions and design as part of the ongoing technical development process.

# REMKO RVT-ARCTIC series

## 14.2 Spare parts list - Indoor unit RVT 264-684 DC IT



### **IMPORTANT!**

*To ensure the correct delivery of spare parts, please always the device type with the corresponding serial number (see type plate)*

No.	Designation
1	Air outlet flap, horizontal
2	Housing front
3	Circuit board, display
4	Ambient air probe
5	Unit trim, bracket right
6	Air filter
7	Evaporator
8	Fan wheel
9	Fan motor
10	Rubber mount, fan wheel
11	IR remote control
12	Control board
13	Evaporator probe
14	Housing part, housing back left
15	Plastic cover, board
16	Condensate drainage line
17	Housing part, housing back right
18	Air outlet flap, vertical
19	Pollen filter
20	Fin motor
21	Housing part, housing back
22	Housing back
23	Wall bracket
24	Remote control mount



### 14.3 Exploded view - Outdoor unit RVT 264-354 DC AT

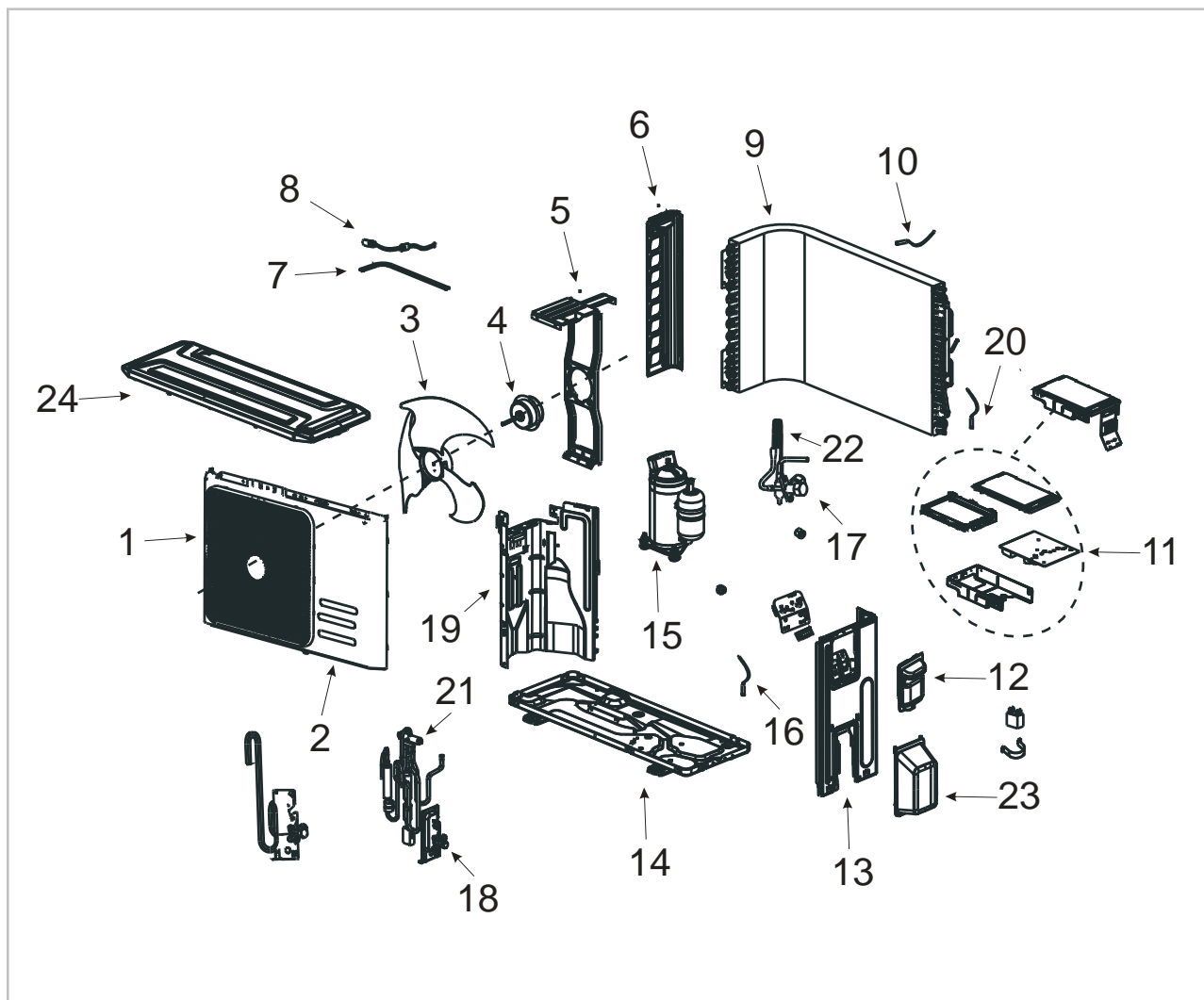

Fig. 63: Exploded view of the unit RVT 264-354 DC AT

We reserve the right to modify the dimensions and design as part of the ongoing technical development process.

# REMKO RVT-ARCTIC series

## 14.4 Spare parts list - Outdoor unit RVT 264-354 DC AT



### **IMPORTANT!**

*To ensure the correct delivery of spare parts, please always the device type with the corresponding serial number (see type plate)*

No.	Designation
1	Condenser protection grille
2	Front panel, condenser
3	Fan blade
4	Fan motor
5	Fan motor mount
6	Side section, left
7	Condensate tray heating
8	Crankcase heating
9	Condenser
10	Condenser outlet temperature probe
11	Control board
12	Cover, electrical connections
13	Side section, right
14	Floor panel
15	Compressor
16	Heat gas probe
17	Shut-off valve, injection pipe
18	Shut-off valve, suction pipe
19	Partitioning panel
20	Condenser temperature probe
21	4-way valve
22	Capillary tube injection
23	Cover, refrigerant connections
24	Cover panel

## 14.5 Exploded view - Outdoor unit RVT 524 DC AT

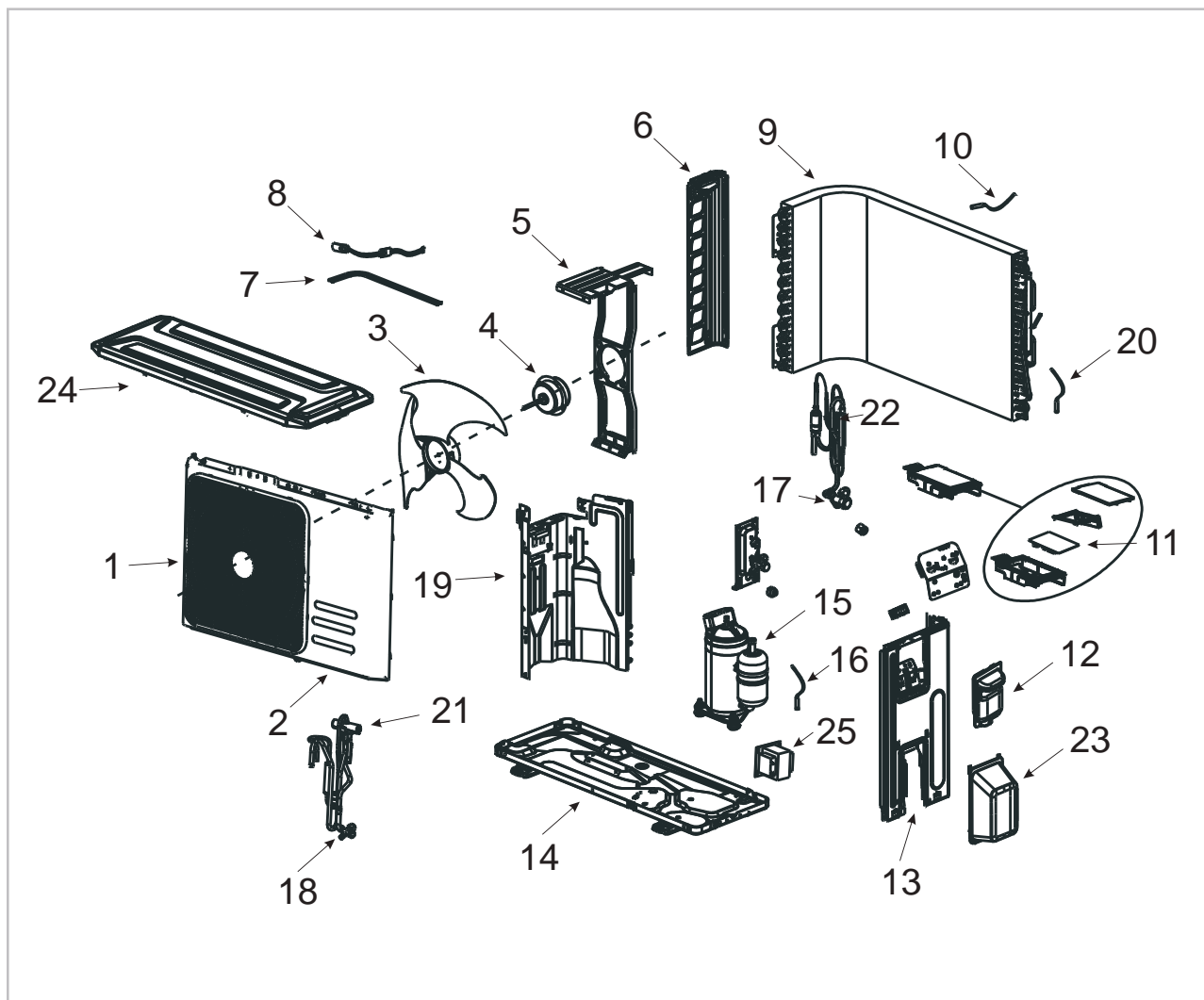

Fig. 64: Exploded view of the unit RVT 524 DC AT

We reserve the right to modify the dimensions and design as part of the ongoing technical development process.

# REMKO RVT-ARCTIC series

## 14.6 Spare parts list - Outdoor unit RVT 524 DC AT

 **IMPORTANT!**

*To ensure the correct delivery of spare parts, please always the device type with the corresponding serial number (see type plate)*

No.	Designation
1	Condenser protection grille
2	Front panel, condenser
3	Fan blade
4	Fan motor
5	Fan motor mount
6	Side section, left
7	Condensate tray heating
8	Crankcase heating
9	Condenser
10	Condenser outlet temperature probe
11	Control board
12	Cover, electrical connections
13	Side section, right
14	Floor panel
15	Compressor
16	Heat gas probe
17	Shut-off valve, injection pipe
18	Shut-off valve, suction pipe
19	Partitioning panel
20	Condenser temperature probe
21	4-way valve
22	Capillary tube injection
23	Cover, refrigerant connections
24	Cover panel

## 14.7 Exploded view - Outdoor unit RVT 684 DC AT

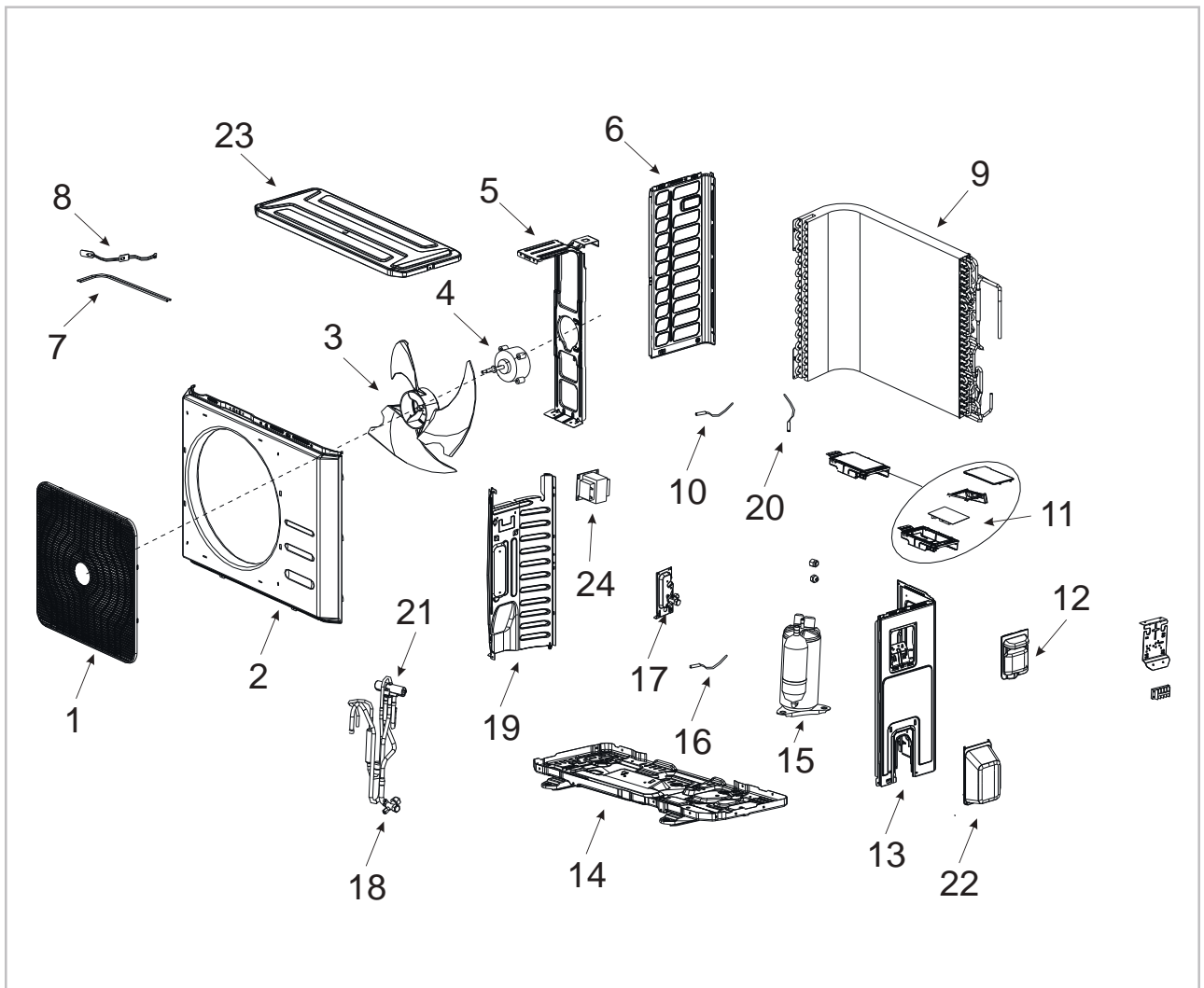

Fig. 65: Exploded view of the unit RVT 684 DC AT

We reserve the right to modify the dimensions and design as part of the ongoing technical development process.

# REMKO RVT-ARCTIC series

## 14.8 Spare parts list - Outdoor unit RVT 684 DC AT



### **IMPORTANT!**

*To ensure the correct delivery of spare parts, please always the device type with the corresponding serial number (see type plate)*

No.	Designation
1	Condenser protection grille
2	Front panel, condenser
3	Fan blade
4	Fan motor
5	Fan motor mount
6	Side section, left
7	Condensate tray heating
8	Crankcase heating
9	Condenser
10	Condenser outlet temperature probe
11	Control board
12	Cover, electrical connections
13	Side section, right
14	Floor panel
15	Compressor
16	Heat gas probe
17	Shut-off valve, injection pipe
18	Shut-off valve, suction pipe
19	Partitioning panel
20	Condenser temperature probe
21	4-way valve
22	Cover, refrigerant connections
23	Cover panel
24	Transformer

## 15 Index

<b>A</b>	
Assembly	
Strip foundation . . . . .	39
<b>C</b>	
Care and maintenance . . . . .	68
Cleaning	
Air filter for indoor unit . . . . .	69
Condensate pump . . . . .	69
Housing . . . . .	69
Condensate drainage connection and safe drainage . . . . .	39
Condensate pump, electrical wiring diagram . .	44
Cooling mode . . . . .	19
<b>D</b>	
Disposal of equipment . . . . .	8
<b>E</b>	
Electrical drawings . . . . .	45, 46, 47
Electrical wiring . . . . .	41
Electrical wiring diagram . . . . .	43
Electrical wiring diagram, condensate pump . .	44
Environmental protection . . . . .	8
Exploded view of the unit . . . . .	71, 73, 75, 77
<b>F</b>	
Fehleranzeige am Innengerät . . . . .	55
Function test of the cooling and heating modes	52
Functional checks . . . . .	51
<b>I</b>	
Infrared remote control . . . . .	21
Installation	
Outdoor unit . . . . .	30
Installation materials . . . . .	29
Intended use . . . . .	7
<b>K</b>	
Keys on the remote control . . . . .	22
Kundendienst . . . . .	53
<b>M</b>	
Maintenance . . . . .	68
Manual mode . . . . .	21
Minimum clearances . . . . .	32
Multifunction board, connection . . . . .	48
<b>O</b>	
Oil return measures . . . . .	33
Ordering spare parts . . . . .	72, 74, 76, 78
<b>P</b>	
Performance charts	
Cooling . . . . .	14, 15, 16, 17
Heating . . . . .	14, 15, 16, 17
Propellant in accordance with Kyoto Protocol . .	11
<b>R</b>	
Remote control	
Keys . . . . .	22
<b>S</b>	
Safe drainage in the event of leakages . . . . .	40
Safety	
Dangers of failure to observe the safety notes . . . . .	6
General . . . . .	5
Identification of notes . . . . .	5
Instructions for the operator . . . . .	6
Note for inspection work . . . . .	6
Note for installation work . . . . .	6
Note for maintenance work . . . . .	6
Personnel qualifications . . . . .	5
Safety-conscious working . . . . .	6
Unauthorised modification . . . . .	7
Unauthorised replacement part manufacture .	7
Shutdown	
Permanent . . . . .	70
Temporary . . . . .	70
Sound level . . . . .	13
Sound power level . . . . .	13
Spare parts list . . . . .	72, 74, 76, 78
Störungen	
Abhilfe . . . . .	53
Mögliche Ursachen . . . . .	53
Überprüfung . . . . .	53
Störungsbeseitigung und Kundendienst . . . . .	53
<b>T</b>	
Test run . . . . .	51
<b>U</b>	
Unit installation . . . . .	35
<b>W</b>	
Wall opening . . . . .	29
Warranty . . . . .	7



# REMKO QUALITY WITH SYSTEMS

Air-Conditioning | Heating | New Energies

**REMKO GmbH & Co. KG**  
**Klima- und Wärmetechnik**

Im Seelenkamp 12  
32791 Lage

Telephone +49 (0) 5232 606-0  
Telefax +49 (0) 5232 606-260

E-mail [info@remko.de](mailto:info@remko.de)  
URL [www.remko.de](http://www.remko.de)

**Hotline within Germany**  
+49 (0) 5232 606-0

**Hotline International**  
+49 (0) 5232 606-130



We reserve the right to make technical changes, and provide no guarantee as to the accuracy of this data!