

# Assembly instructions

**REMKO noise protection hood SWK 4, SWK 5, SWK 7  
for REMKO heat pumps**





**Read these operating instructions carefully before commissioning / using this device!**

**These instructions are an integral part of the system and must always be kept near or on the device.**

Subject to modifications; No liability accepted for errors or misprints!

**Translation of the original assembly instructions**

## Table of contents

<b>1</b>	<b>Safety and usage instructions</b> .....	<b>4</b>
1.1	General safety notes.....	4
1.2	Identification of notes.....	4
1.3	Personnel qualifications.....	4
1.4	Dangers of failure to observe the safety notes.....	4
1.5	Safety-conscious working.....	5
1.6	Safety instructions for the operator.....	5
1.7	Safety notes for installation and inspection tasks.....	5
1.8	Unauthorised modification and changes.....	5
1.9	Intended use.....	5
1.10	Guarantee.....	6
1.11	Transport and packaging.....	6
1.12	Environmental protection and recycling.....	6
<b>2</b>	<b>Technical data</b> .....	<b>7</b>
2.1	Noise protection hood dimensions.....	7
2.2	Dimensions for noise protection hoods with outdoor units.....	10
2.3	Product data.....	11
2.4	Fire classification.....	11
2.5	Reduce the sound power level .....	12
<b>3</b>	<b>Product description</b> .....	<b>18</b>
<b>4</b>	<b>Setting up the outdoor unit and the noise protection hood</b> .....	<b>19</b>
<b>5</b>	<b>Design of the noise protection hood</b> .....	<b>24</b>
<b>6</b>	<b>Exploded view of product and spare parts</b> .....	<b>35</b>
6.1	Exploded view of and spare parts list for noise protection hood SWK 4.....	35
6.2	Exploded view of and spare parts list for noise protection hood SWK 5.....	38
6.3	Exploded view of and spare parts list for noise protection hood SWK 7.....	41
<b>7</b>	<b>Index</b> .....	<b>44</b>

# REMKO noise protection hood

## 1 Safety and usage instructions

### 1.1 General safety notes

Carefully read the operating manual before installing the accessory item. It provides useful tips and notes such as hazard warnings to prevent injury and material damage. Failure to follow the directions in this manual can endanger persons, the environment and the equipment itself or its components and will void any claims for liability.

Keep this operating manual close to the accessory item.

#### NOTICE!

The noise protection hood must never be cleaned using a high pressure cleaner!

Do not use any sharp objects for cleaning!

### 1.2 Identification of notes

This section provides an overview of all important safety aspects for proper protection of people and safe and fault-free operation. The instructions and safety notes contained within this manual must be observed in order to prevent accidents, personal injury and material damage.

Notes attached directly to the accessory items must be observed in their entirety and be kept in a fully legible condition.

Safety notes in this manual are indicated by symbols. Safety notes are introduced with signal words which help to highlight the magnitude of the danger in question.

#### DANGER!

Contact with live parts poses an immediate danger of death due to electric shock. Damage to the insulation or individual components may pose a danger of death.

#### DANGER!

This combination of symbol and signal word warns of a situation in which there is immediate danger, which if not avoided may be fatal or cause serious injury.

#### WARNING!

This combination of symbol and signal word warns of a potentially hazardous situation, which if not avoided may be fatal or cause serious injury.

#### CAUTION!

This combination of symbol and signal word warns of a potentially hazardous situation, which if not avoided may cause injuries or material and environmental damage.

#### NOTICE!

This combination of symbol and signal word warns of a potentially hazardous situation, which if not avoided may cause material and environmental damage.



*This symbol highlights useful tips and recommendations as well as information for efficient and fault-free operation.*

### 1.3 Personnel qualifications

Personnel responsible for commissioning, operation, maintenance, inspection and installation must be able to demonstrate that they hold a qualification which proves their ability to undertake the work.

### 1.4 Dangers of failure to observe the safety notes

Failure to observe the safety notes may pose a risk to people, the environment and the units. Failure to observe the safety notes may void any claims for damages.

In particular, failure to observe the safety notes may pose the following risks:

- The failure of important unit functions.
- The failure of prescribed methods of maintenance and repair.
- Danger to people on account of electrical and mechanical effects.

## 1.5 Safety-conscious working

The safety notes contained in this manual, the existing national regulations concerning accident prevention as well as any internal company working, operating and safety regulations must be observed.

## 1.6 Safety instructions for the operator

The operational safety of the units and components is only assured providing they are used as intended and in a fully assembled state.

- The units and components may only be set up, installed and maintained by qualified personnel.
- The existing regulations concerning accident prevention must be adhered to.
- Do not operate units or components with obvious defects or signs of damage.
- Contact with equipment parts or components can lead to injuries.
- Ensure that electrical energy does not pose a risk.
- Regulations of the VDE and the local energy supply company must be adhered to.

### ! NOTICE!

The noise protection hood must never be cleaned using a high pressure cleaner!

Do not use any sharp objects for cleaning!

### ! NOTICE!

#### Material damage due to mineral oils!

Mineral oil products permanently damage EPDM seal elements; the sealing properties may therefore be lost. We do not take responsibility or provide warranty replacements for damage caused by seals that are damaged in this way.

- It is essential that you prevent EPDM from coming into contact with mineral oil substances.
- Use a lubricant that is free of mineral oil and has a silicone or polyalkylene basis, such as Unisilikon L250L and Syntheso Glep 1 made by Klüber, or a silicon spray.

## 1.7 Safety notes for installation and inspection tasks

- The operator must ensure that all inspection and installation work is carried out by authorised and qualified personnel who have thoroughly read the operating manual.
- Work on the noise protection hood may only ever be carried out when the system is stationary.
- Appropriate hazard prevention measures must be taken to prevent risks to people when performing installation, repair, maintenance or cleaning work on the units.
- The setup, connection and operation of the units and its components must be undertaken in accordance with the usage and operating conditions stipulated in this manual and comply with all applicable regional regulations.
- Regional regulations and laws as well as the Water Ecology Act must be observed.
- The units and components must be kept at an adequate distance from flammable, explosive, combustible, abrasive and dirty areas or atmospheres.

### ! CAUTION!

Ensure that the outdoor unit is shut down and secured to prevent a restart during the installation, maintenance and repair times in order to prevent injuries caused by the fan starting up!

## 1.8 Unauthorised modification and changes

The operational safety of the noise protection hood that was delivered is guaranteed only when used as intended.

Modifications or changes to units and components are not permitted and may cause malfunctions. Original replacement parts and accessories authorised by the manufacturer ensure safety. The use of other parts may invalidate liability for resulting consequences.

## 1.9 Intended use

The noise protection hood is only intended as a noise and weather protector for outdoor units on the heat pumps.

Any different or additional use is a non-intended use. The manufacturer/supplier assumes no liability for damages arising from non-intended use. The user bears the sole risk in such cases. Intended use also includes working in accordance with the operating and installation instructions and complying with the maintenance requirements.

# REMKO noise protection hood

The threshold values specified in the technical data must not be exceeded.

## 1.10 Guarantee

As a prerequisite for any guarantee claims to be considered, it is essential that the ordering party or its representative complete and return the "certificate of warranty" to REMKO GmbH & Co. KG at the time when the units are purchased and commissioned. The warranty conditions are listed in the "General terms and conditions". Furthermore, only the parties to a contract can conclude special agreements beyond these conditions. In this case, contact your contractual partner in the first instance.

## 1.11 Transport and packaging

The items are shipped in sturdy transport packaging. Immediately check the components upon delivery and make a note of any damage or missing parts on the delivery note. Inform the forwarding agent and contractual partner. Claims under guarantee made at a later date will not be accepted.

### **WARNING!**

**Plastic films and bags etc. are dangerous toys for children!**

Why:

- Leave packaging material are not around.
- Packaging material may not be accessible to children!

### **NOTICE!**

Sharp objects will damage the noise protection hood's surface.

Remove the packaging carefully!

## 1.12 Environmental protection and recycling

### Disposing of packaging

All products are packed for transport in environmentally friendly materials. Make a valuable contribution to reducing waste and sustaining raw materials. Only dispose of packaging at approved collection points.



### Disposing of the units and their components

For the manufacture of the units and components, only recyclable materials have been used. Help protect the environment by ensuring that the units or components (for example batteries) are not disposed of in household waste, but only in accordance with local regulations and in an environmentally safe manner, e.g. using authorised disposal and recycling specialists or council collection points.



## 2 Technical data

### 2.1 Noise protection hood dimensions

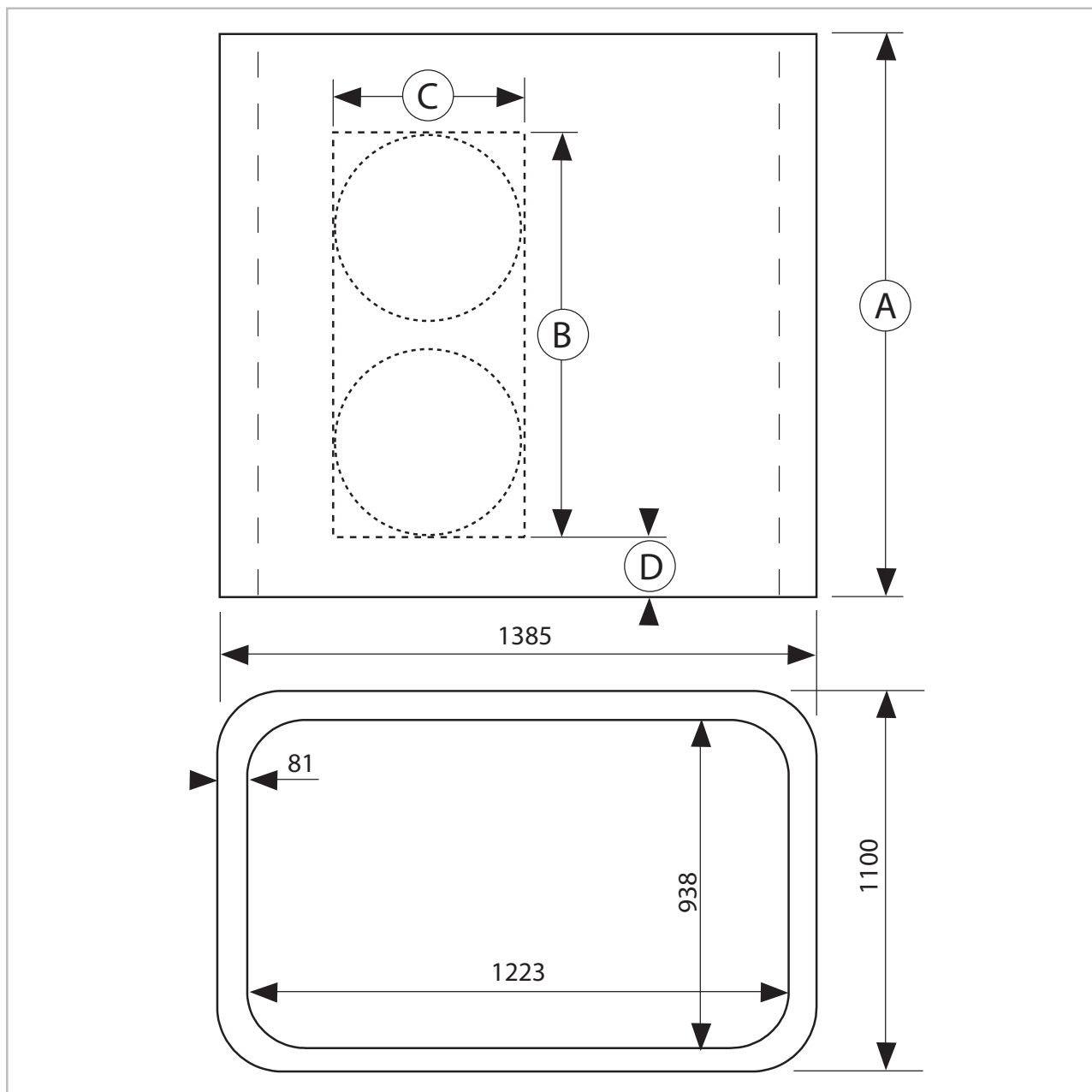

Fig. 1: Noise protection hood dimensions (all dimensions in mm)

Series	SWK 4	SWK 5	SWK 7
Heat pump type	WKF 70	WKF 120	WKF 180
A (External dimensions)	1155	1400	1880
B	500	615	1260
C	565	570	570
D	275	405	315

# REMKO noise protection hood

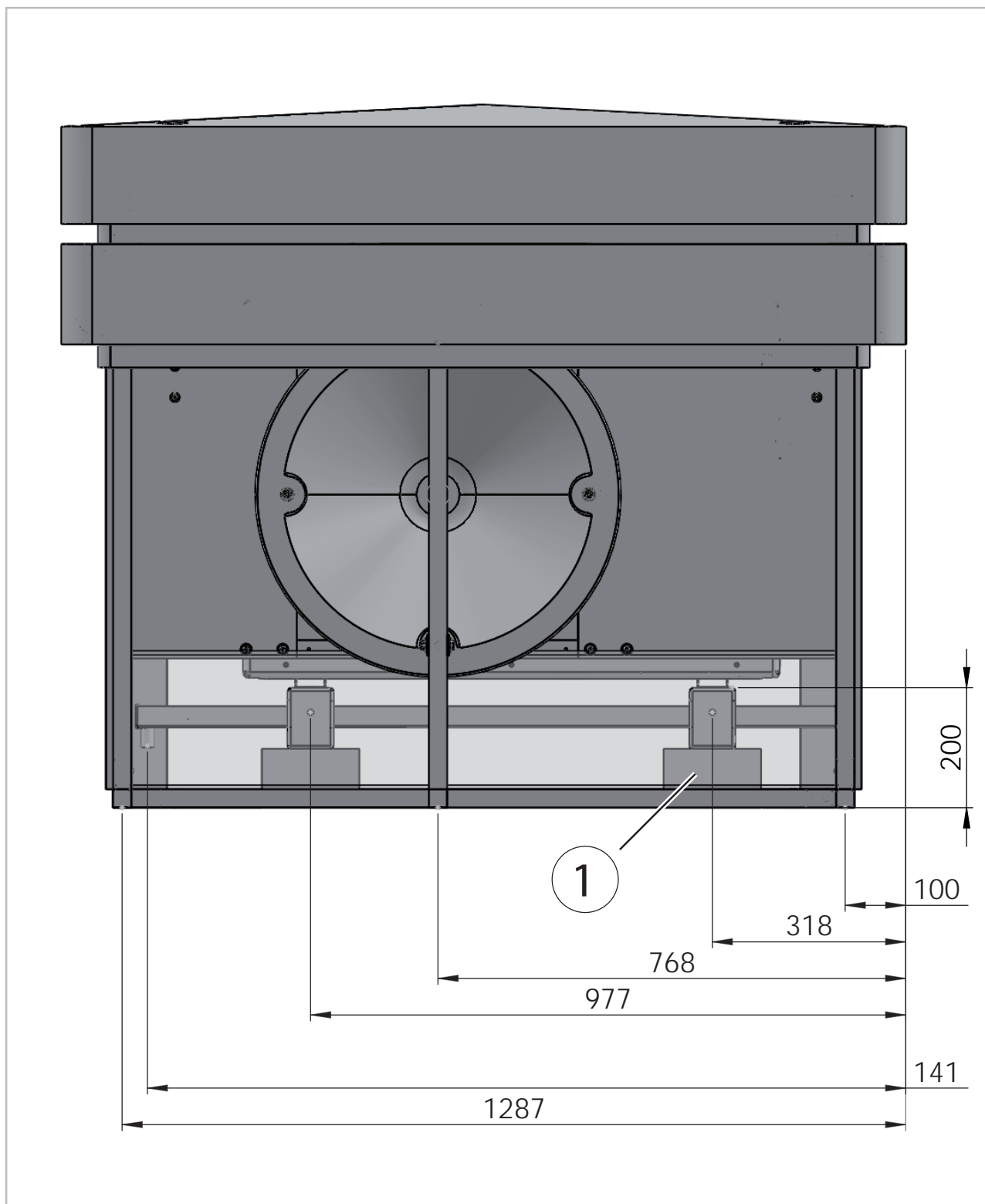

Fig. 2: Front view noise protection hood SWK 4 (all dimensions in mm)

1: Floor bracket BK 600



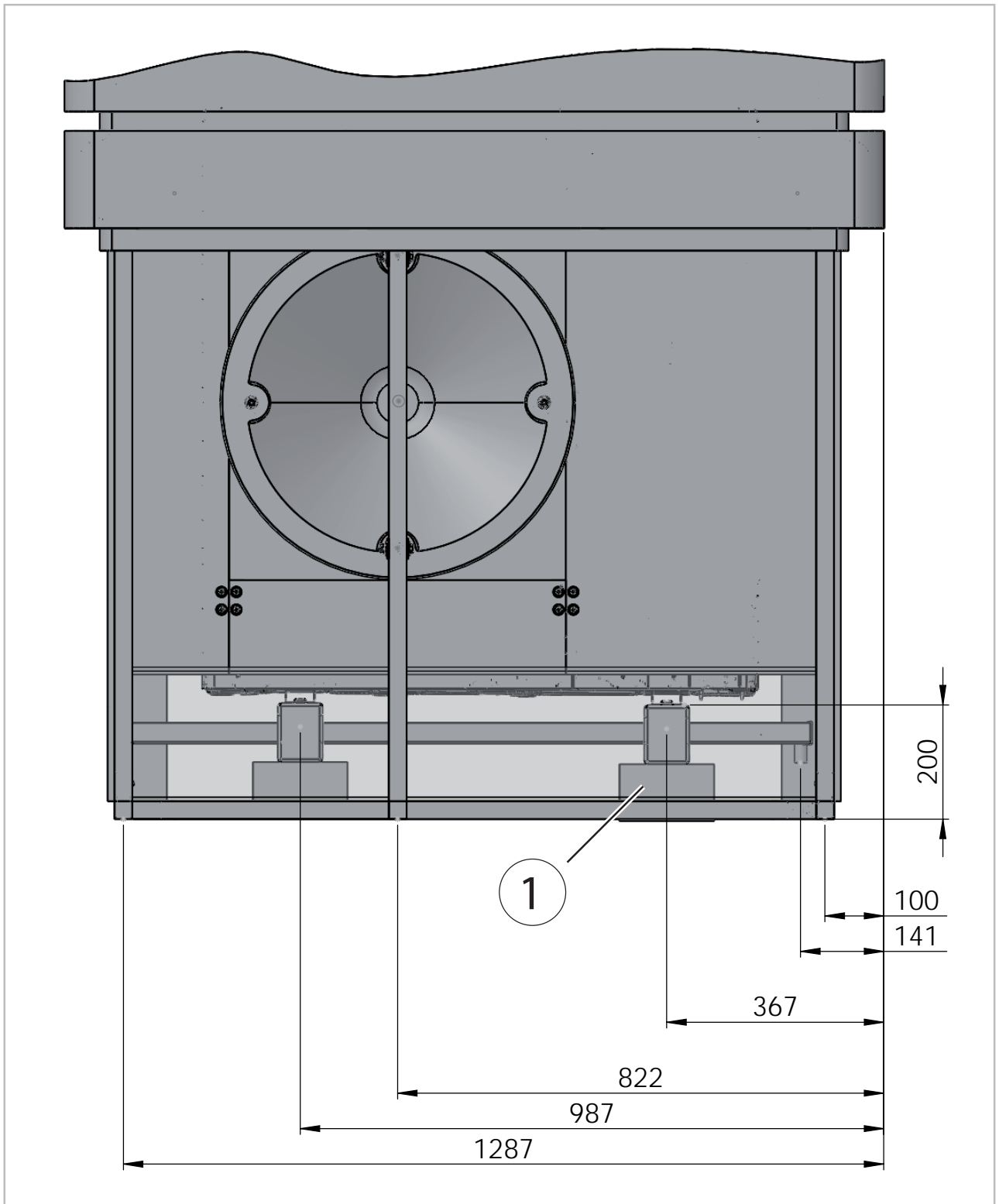

Fig. 3: Front view noise protection hood SWK 5 and SWK 7 (all dimensions in mm)

1: Floor bracket BK 600

# REMKO noise protection hood

## 2.2 Dimensions for noise protection hoods with outdoor units

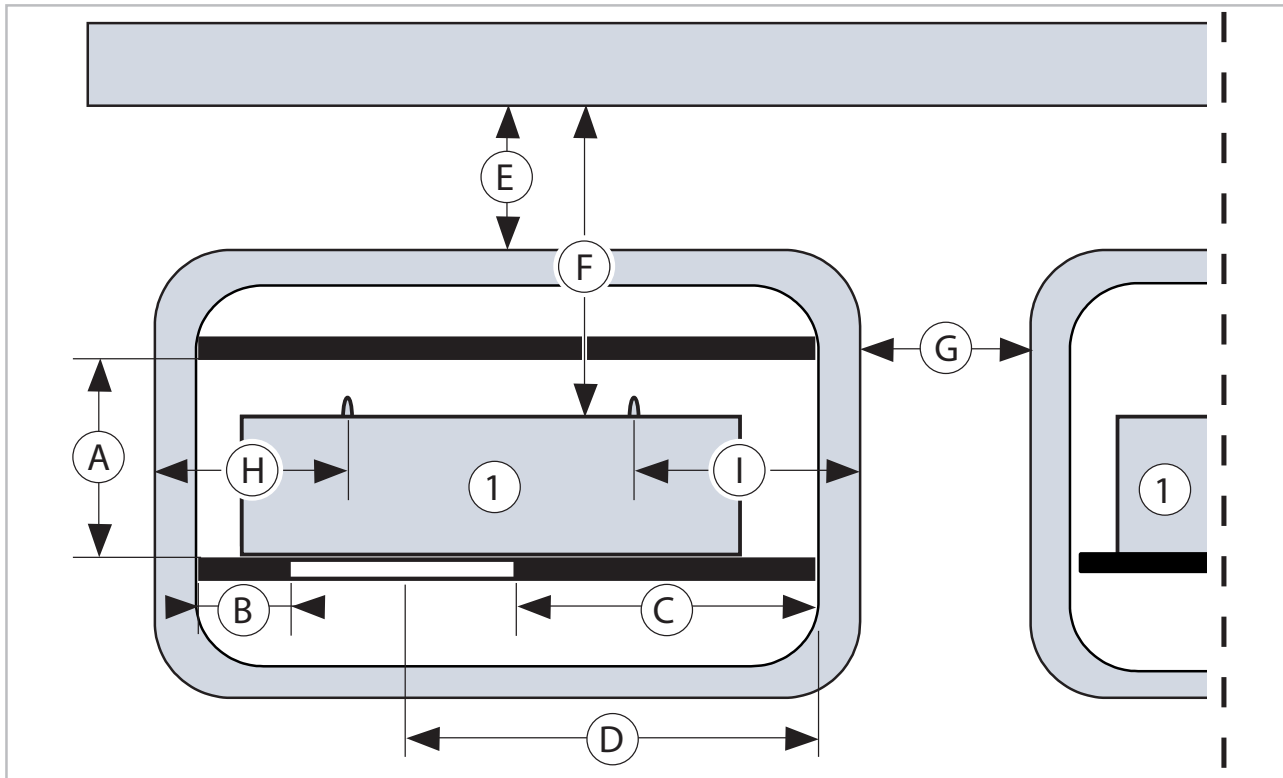

Fig. 4: Dimensions for noise protection hoods with outdoor units

Series	SWK 4	SWK 5	SWK 7
Heat pump type	WKF 70	WKF 120	WKF 180
1	Outdoor unit		
A	510		
B	304	198	195
C	454	452	455
D - to fan middle	687	739	741
<b>Minimum distances</b>			
E - to building wall	300		
F - from outdoor unit to building wall	700		
G - between two noise protection hoods	1000		
H - from the outside edge of the hood to the foot middle of the unit	407	393	
I - from the outside edge of the hood to the foot middle of the unit	318	372	
From the unit's bottom edge to the top edge of the solid base (see Fig. 7)	200		

All dimensions in mm

## 2.3 Product data

Series		SWK 4	SWK 5	SWK 7
Heat pump type		WKF 70	WKF 120	WKF 180
Noise suppression material		EPP-polypropylene		
Tonality	dB(A)	omitted		
Fire protection class EPP <sup>1)</sup>		B2		
<b>Hood dimensions</b>				
Height	mm	1155	1400	1880
Width	mm	1385		
Depth	mm	1100		
Weight	kg	40	43	48

<sup>1)</sup> You will find further information in the safety data sheets; we shall be happy to provide these.

We reserve the right to make technical changes in connection with technical advancement.

## 2.4 Fire classification

### Fire behaviour of building materials and components (DIN 4102-1)

In DIN 4102-01, differentiation is made between non-combustible (A1, A2) and combustible (B1, B2, B3) building materials. This concerns the vertical flame treatment of the test specimens. In addition to the fire speed, a fire shaft test (flue gas temperature) is also conducted for the B1 classification.

EPP is classified among the combustible building materials, which can be sub-categorised as follows:

- not easily combustible B1
- flammable B2
- easily flammable B3

### Current listing according to DIN 4102-1 for EPP standard

Thick-ness of the panel sec-tions	Density [kg/m <sup>3</sup> ]			
	30	40	60	80
10 mm	B3	B3	B3/B2*	B2
20 mm	B3/B2*	B2	B2	B2
30 mm	B2	B2	B2	B2

\* With use with covered edges, building material class B2

### Current listing according to DIN 4102-1/-16 for EPP FR

B1 (thickness: 10-40 mm, density: 40-60 g/L)

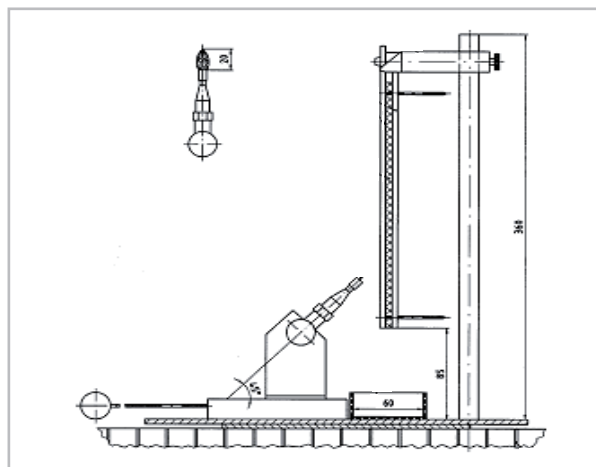

Fig. 5: Assembly for the vertical flame treatment of the test specimens

### Remark:

The information provided here is based on our current knowledge and experience. It does not release the user from conducting their own tests and investigations, due to possible influential factors of the particle foam moulded parts or other components present in the vicinity. It is not possible to derive any legally binding assurance of specific characteristics or suitability for a certain application case from this technical data. It is the sole responsibility of the recipient of our products to check for any infringements of industrial property rights, laws and provisions.

# REMKO noise protection hood

## 2.5 Reduce the sound power level

Reduce the sound power level of a WKF 70 <sup>1)</sup> with the sound absorption hood SWK 4

Middle frequen. [Hz]	100	125	160	200	250	315	400	500	630	800
<b>Measuring results from independent test report <sup>2)</sup></b>										
Sound power level $L_{WA}$ [dB(A)]	37,9	39,1	47,2	46,7	49,3	57,2	52,8	52,0	52,7	53,9
<b>Measuring results with the sound absorption hood <sup>3),4)</sup></b>										
Sound power level $L_{WA}$ [dB(A)]	48,0	46,0	45,3	44,8	43,1	44,5	44,1	45,2	46,3	46,1

Middle frequen. [Hz]	1000	1250	1600	2000	2500	3150	4000	5000	6300	Total
<b>Measuring results from independent test report <sup>2)</sup></b>										
Sound power level $L_{WA}$ [dB(A)]	52,5	51,5	50,0	50,0	47,9	45,5	42,8	40,4	38,0	<b><u>63,2</u></b>
<b>Measuring results with the sound absorption hood <sup>3),4)</sup></b>										
Sound power level $L_{WA}$ [dB(A)]	44,7	42,8	41,2	39,7	37,7	35,3	34,9	31,9	35,0	<b><u>56,7</u></b>

<sup>1)</sup> Compressor frequency 54 Hz

<sup>2)</sup> Measurement in accordance with DIN EN ISO 9614-2 (12/1996) and DIN EN 12102 (09/2008)

<sup>3)</sup> Measurement in accordance with DIN EN ISO 3744

<sup>4)</sup> Less the measurement uncertainty of 4 dB(A) in accordance with DIN EN ISO 3744

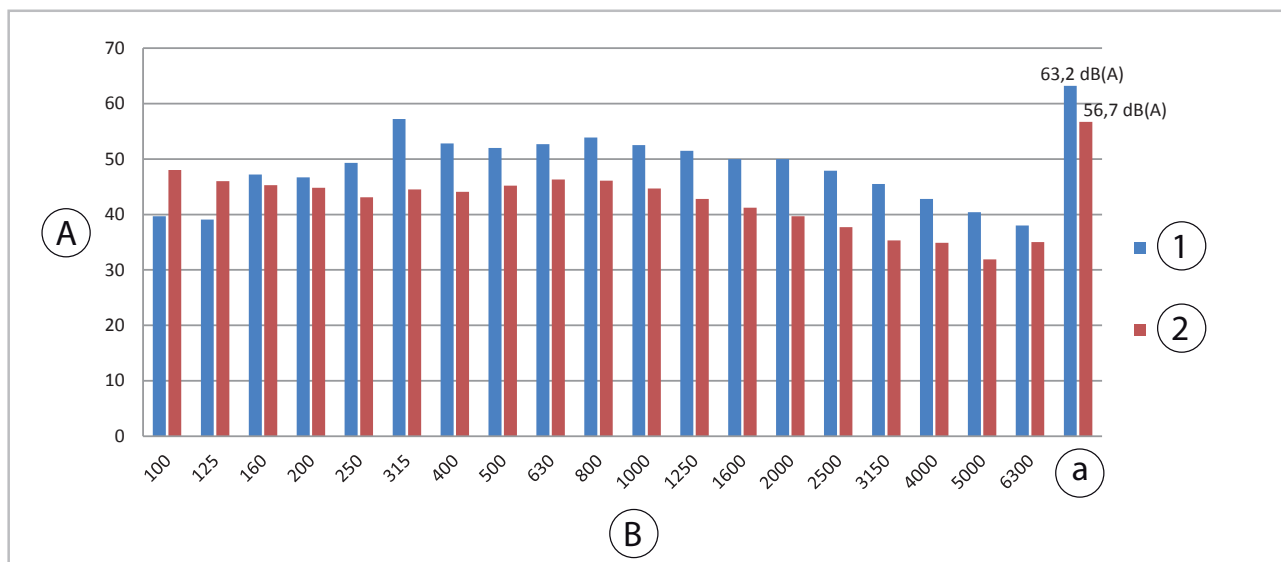

A: Sound power level  $L_{WA}$  [dB(A)]

B: Middle frequency [Hz]

a: Sound power level total

1: Measuring results independent test report

2: Measuring results with the sound absorption hood

**Sound power level of a WKF 70 with a compressor frequency of 81 Hz with the sound absorption hood SWK 4**

Middle frequen. [Hz]	630	800	1000	1250	1600	2000
<b>Measuring results with the sound absorption hood <sup>3),4),5)</sup></b>						
Sound power level $L_{WA}$ [dB(A)]	46,4	47,4	46,0	42,8	41,3	38,8

Middle frequen. [Hz]	2500	3150	4000	5000	6300	Total
<b>Measuring results with the sound absorption hood <sup>3),4),5)</sup></b>						
Sound power level $L_{WA}$ [dB(A)]	37,2	35,5	36,3	30,3	29,0	<u>52,9</u>

<sup>3)</sup> Measurement in accordance with DIN EN ISO 3744

<sup>4)</sup> Less the measurement uncertainty of 4 dB(A) in accordance with DIN EN ISO 3744

<sup>5)</sup> Less room adjustment of 3.3 dB(A) assuming an absolute comparative measurement with the use of a comparable sound source in accordance with DIN EN ISO 3744

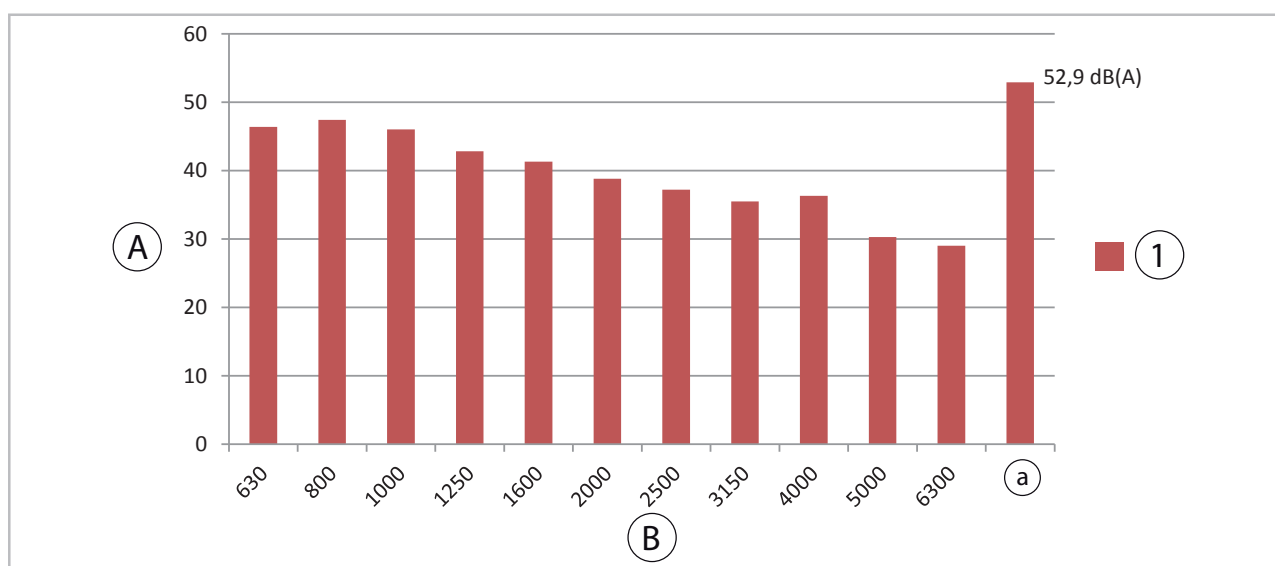

A: Sound power level  $L_{WA}$  [dB(A)]

B: Middle frequency [Hz]

a: Sound power level total

1: Measuring results with the sound absorption hood

# REMKO noise protection hood

Reduce the sound power level of a WKF 120 <sup>1)</sup> with the sound absorption hood SWK 5

Middle frequen. [Hz]	100	125	160	200	250	315	400	500	630	800
<b>Measuring results from independent test report <sup>2)</sup></b>										
Sound power level $L_{WA}$ [dB(A)]	49,9	54,3	50,5	54,9	62,7	55,7	55,9	54,6	57,4	57,1
<b>Measuring results with the sound absorption hood <sup>3),4)</sup></b>										
Sound power level $L_{WA}$ [dB(A)]	43,0	48,6	42,5	46,1	56,7	48,8	45,0	45,8	46,4	50,3

Middle frequen. [Hz]	1000	1250	1600	2000	2500	3150	4000	5000	6300	Total
<b>Measuring results from independent test report <sup>2)</sup></b>										
Sound power level $L_{WA}$ [dB(A)]	59,0	54,3	52,3	49,9	47,2	44,8	41,7	36,1	33,3	<b>67,9</b>
<b>Measuring results with the sound absorption hood <sup>3),4)</sup></b>										
Sound power level $L_{WA}$ [dB(A)]	46,3	43,1	40,7	35,4	34,3	33,1	29,8	26,3	25,5	<b>60,2</b>

1) Compressor frequency 60 Hz

2) Measurement in accordance with DIN EN ISO 9614-2 (12/1996) and DIN EN 12102 (09/2008)

3) Measurement in accordance with DIN EN ISO 3744

4) Less the measurement uncertainty of 4 dB(A) in accordance with DIN EN ISO 3744

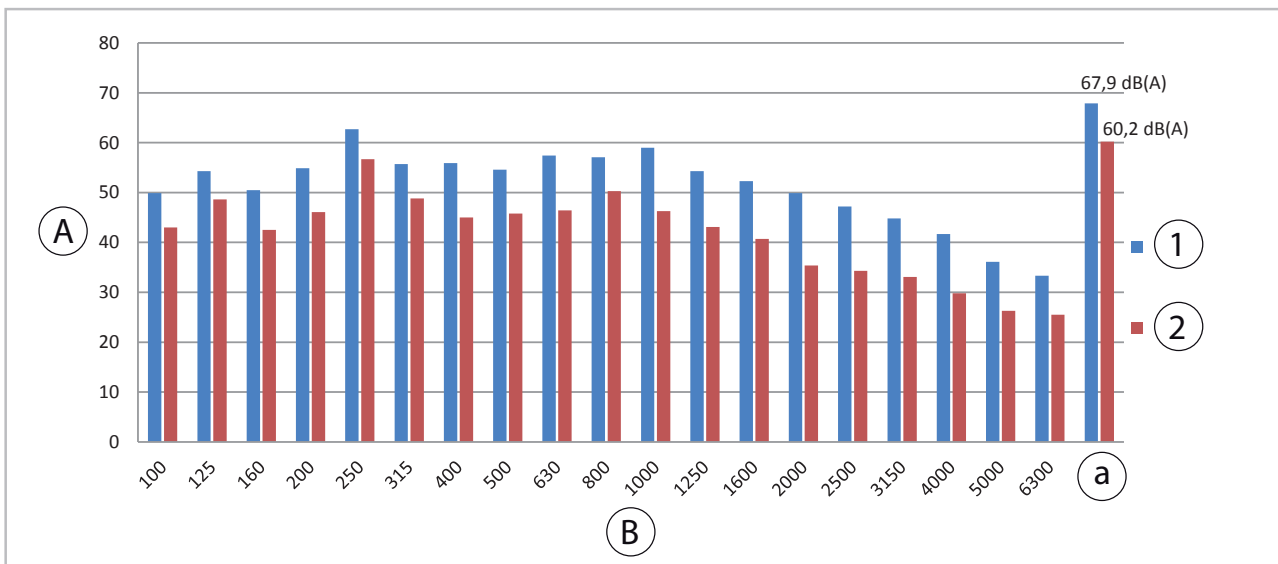

A: Sound power level  $L_{WA}$  [dB(A)]

B: Middle frequency [Hz]

a: Sound power level total

1: Measuring results independent test report

2: Measuring results with the sound absorption hood

**Sound power level of a WKF 120 with a compressor frequency of 90 Hz with the sound absorption hood SWK 5**

Middle frequen. [Hz]	630	800	1000	1250	1600	2000
<b>Measuring results with the sound absorption hood <sup>3),4),5)</sup></b>						
Sound power level $L_{WA}$ [dB(A)]	54,7	54,4	52,2	48,3	47,3	43,6

Middle frequen. [Hz]	2500	3150	4000	5000	6300	Total
<b>Measuring results with the sound absorption hood <sup>3),4),5)</sup></b>						
Sound power level $L_{WA}$ [dB(A)]	41,3	39,7	38,5	37,5	33,1	<u>59,6</u>

<sup>3)</sup> Measurement in accordance with DIN EN ISO 3744

<sup>4)</sup> Less the measurement uncertainty of 4 dB(A) in accordance with DIN EN ISO 3744

<sup>5)</sup> Less room adjustment of 3.3 dB(A) assuming an absolute comparative measurement with the use of a comparable sound source in accordance with DIN EN ISO 3744

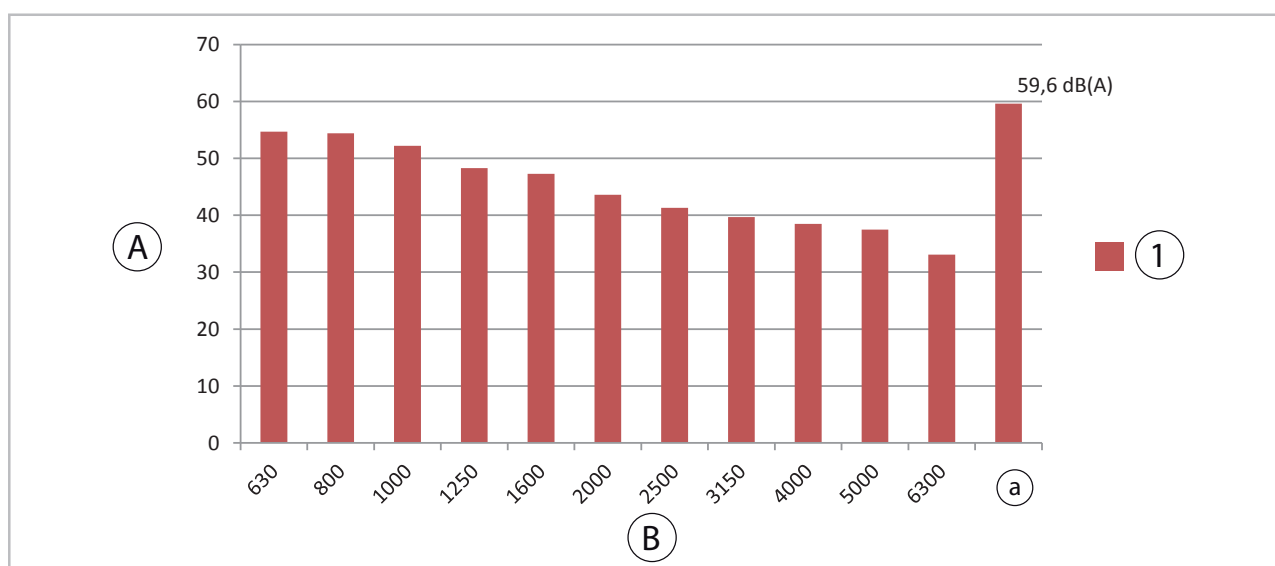

A: Sound power level  $L_{WA}$  [dB(A)]

B: Middle frequency [Hz]

a: Sound power level total

1: Measuring results with the sound absorption hood

# REMKO noise protection hood

Reduce the sound power level of a WKF 180 <sup>1)</sup> with the sound absorption hood SWK 7

Middle frequen. [Hz]	100	125	160	200	250	315	400	500	630	800
<b>Measuring results from independent test report <sup>2)</sup></b>										
Sound power level $L_{WA}$ [dB(A)]	60,4	56,3	61,1	54,8	55,1	56,4	55,3	55,4	56,9	57,8
<b>Measuring results with the sound absorption hood <sup>3),4)</sup></b>										
Sound power level $L_{WA}$ [dB(A)]	48,9	48,8	51,2	49,7	50,2	51,1	51,8	53,1	53,7	55,1

Middle frequen. [Hz]	1000	1250	1600	2000	2500	3150	4000	5000	6300	Total
<b>Measuring results from independent test report <sup>2)</sup></b>										
Sound power level $L_{WA}$ [dB(A)]	58,9	52,4	49,2	46,0	43,6	40,9	37,0	32,1	28,0	<b>68,3</b>
<b>Measuring results with the sound absorption hood <sup>3),4)</sup></b>										
Sound power level $L_{WA}$ [dB(A)]	51,3	48,6	46,7	43,4	40,6	38,5	36,1	34,8	32,5	<b>62,8</b>

<sup>1)</sup> Compressor frequency 56 Hz

<sup>2)</sup> Measurement in accordance with DIN EN ISO 9614-2 (12/1996) and DIN EN 12102 (09/2008)

<sup>3)</sup> Measurement in accordance with DIN EN ISO 3744

<sup>4)</sup> Less the measurement uncertainty of 4 dB(A) in accordance with DIN EN ISO 3744

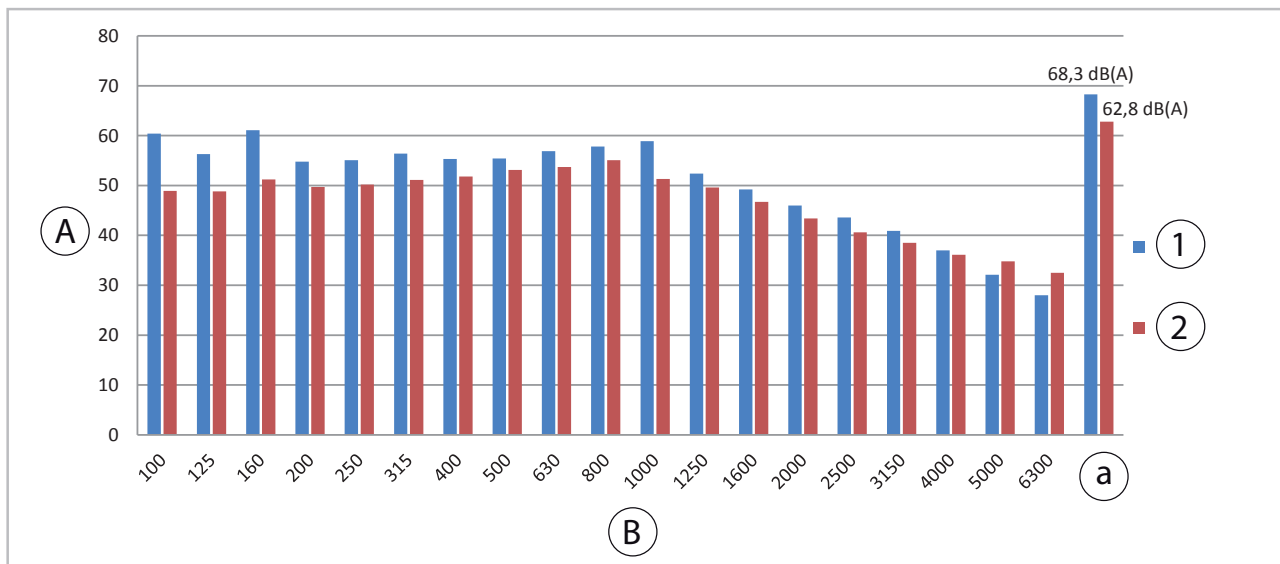

A: Sound power level  $L_{WA}$  [dB(A)]

B: Middle frequency [Hz]

a: Sound power level total

1: Measuring results independent test report

2: Measuring results with the sound absorption hood



**Sound power level of a WKF 180 with a compressor frequency of 84 Hz with the sound absorption hood SWK 7**

Middle frequen. [Hz]	630	800	1000	1250	1600	2000
<b>Measuring results with the sound absorption hood <sup>3),4),5)</sup></b>						
Sound power level $L_{WA}$ [dB(A)]	60,0	58,7	55,9	54,5	53,2	50,3

Middle frequen. [Hz]	2500	3150	4000	5000	6300	Total
<b>Measuring results with the sound absorption hood <sup>3),4),5)</sup></b>						
Sound power level $L_{WA}$ [dB(A)]	47,8	45,5	43,0	41,7	39,6	<b><u>64,6</u></b>

<sup>3)</sup> Measurement in accordance with DIN EN ISO 3744

<sup>4)</sup> Less the measurement uncertainty of 4 dB(A) in accordance with DIN EN ISO 3744

<sup>5)</sup> Less room adjustment of 3.3 dB(A) assuming an absolute comparative measurement with the use of a comparable sound source in accordance with DIN EN ISO 3744

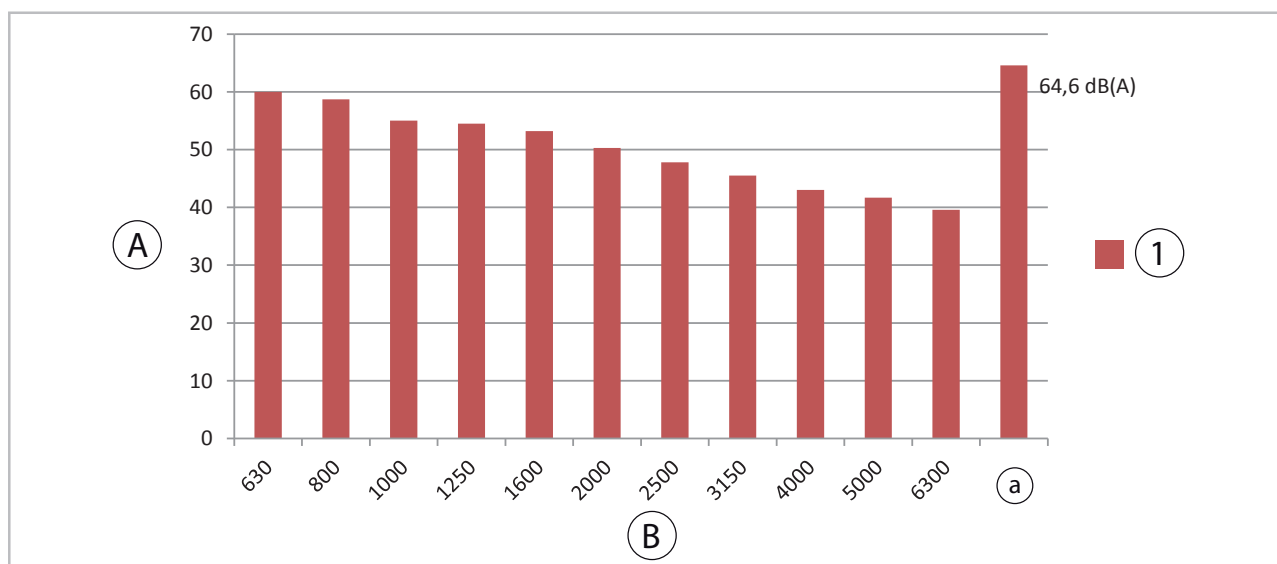

A: Sound power level  $L_{WA}$  [dB(A)]

B: Middle frequency [Hz]

a: Sound power level total

1: Measuring results with the sound absorption hood

# REMKO noise protection hood

## 3 Product description

The noise protection hood is suitable for use in regions with high requirements for low noise emissions. The EPP housing, the specially-developed air intake and air outlet openings reduce noise significantly, which also enables installation in residential areas. The complete encapsulation protects the heat pump against the effects of weather such as hail, UV radiation and snow, as well as against external damage or vandalism. The simple layout thanks to the modular construction ensures easy installation and fast access to the unit.

Features/equipment:

- Simple installation thanks to the modular construction; suitable for use in conjunction with REMKO WKF 70, 120, 180 and 180 DUO heat pump outdoor units.
- Black or silver and black housing colour
- Sound power level reduction of up to 15 dB(A)

A proper installation surface for stability with the option to affix the sound protection hood and protection against plant growth from below must be guaranteed.

The customer must provide suitable options for frost-proof removal of the condensate that accumulates.

## 4 Setting up the outdoor unit and the noise protection hood

### Protection against wind

Protect the soundproofing hood against wind in windy areas, in the open air or on flat roofs.

Stabilise the soundproofing hood, e.g. with wire ropes, tension belts or other constructions.

Anchor your construction firmly in the ground.

### ! NOTICE!

During installation, make sure that no damage is caused by tensile forces!

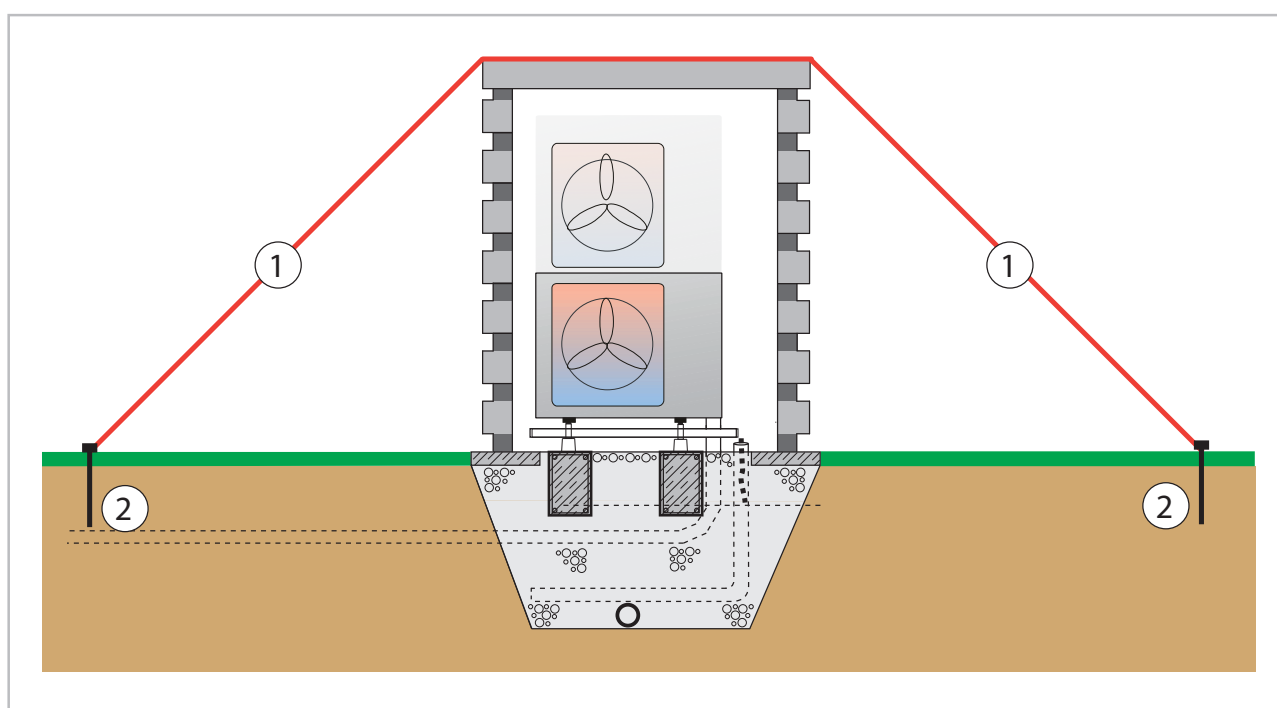

Fig. 6: Protection against wind

- 1: Stabilising construction
- 2: Ground anchoring

# REMKO noise protection hood

## Strip foundations

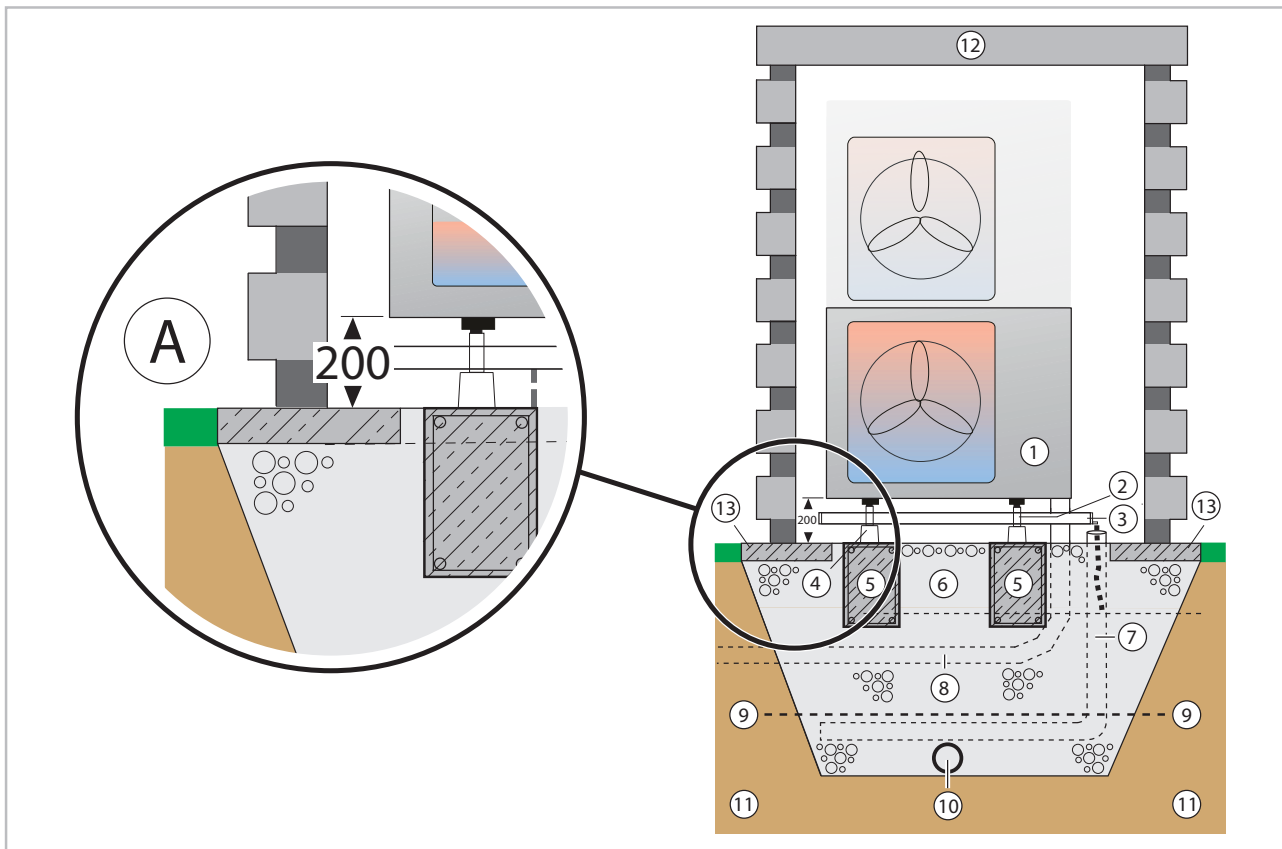

Fig. 7: Condensate drainage, seepage of condensate and strip foundation (cross-section)

- |  |   |
|--|---|
| 1: Outdoor unit  | 8: Conduit for refrigerant piping and electrical connecting line (temperature-resistant up to at least 80 °C) |
| 2: Feet for condensate catch pan                         | 9: Frost line   |
| 3: Condensate catch pan including pan heater             | 10: Drainage pipe   |
| 4: Floor bracket   | 11: Soil  |
| 5: Reinforced strip foundation<br>HxWxD = 300x160x600 mm | 12: Noise protection hood   |
| 6: Gravel layer for seepage                              | 13: Solid base (e.g. concrete plates)   |
| 7: Drainage channel                                      |   |

### ! NOTICE!

There must be a gap of 200 mm between the outdoor unit's bottom edge and the hood's bottom edge!

(see detailed illustration A)

### ! NOTICE!

The refrigerant lines must enter the housing from the rear, side or front with the use of the REMKO OA2 oil separator.

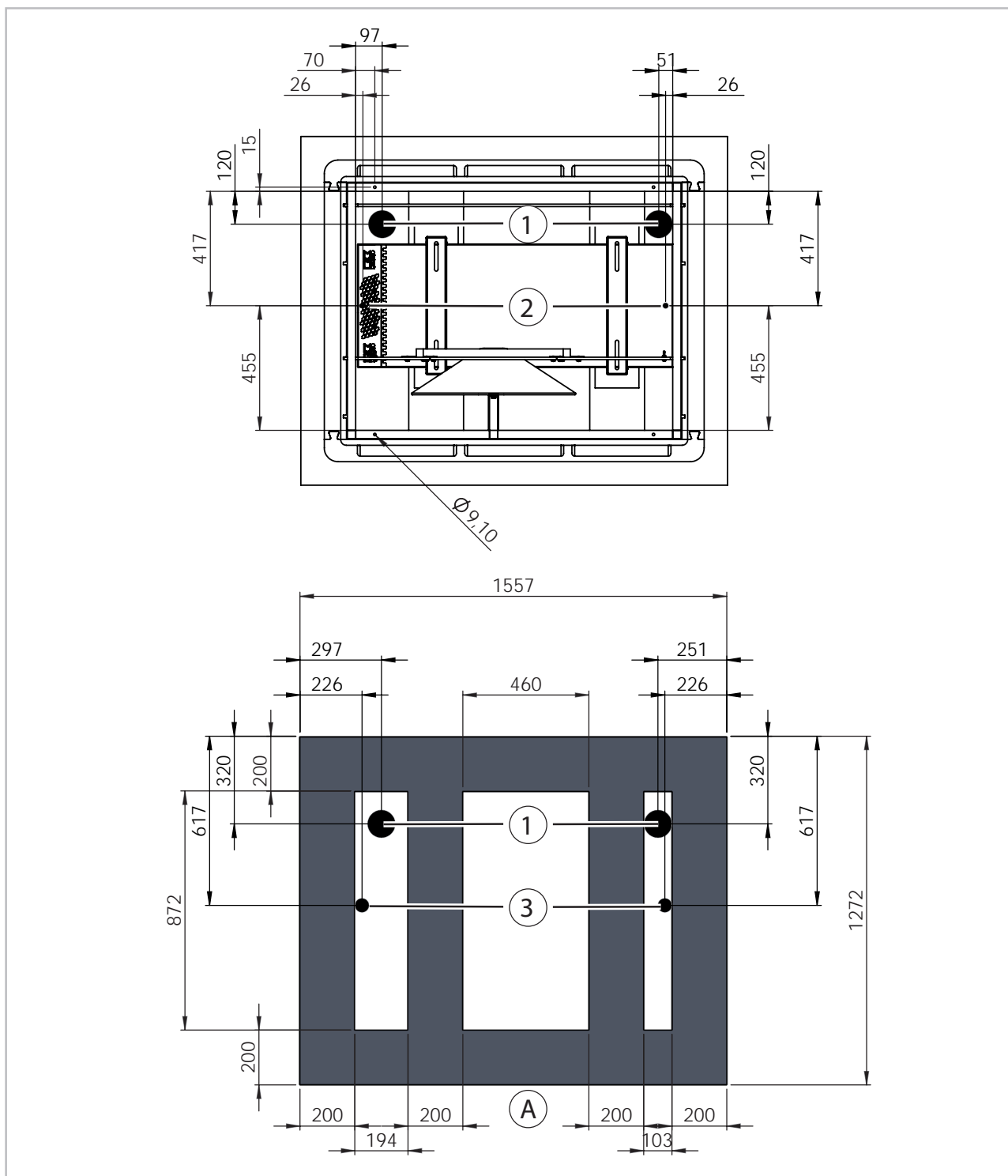

Fig. 8: Strip foundation SWK 4

- A: Outdoor unit, fan side
- 1: Protection tube, optionally right or left  $\varnothing$  100 mm
- 2: Condensate drain connection, optionally right or left min.  $\varnothing$  20 mm
- 3: Condensate drain, optionally left or right min.  $\varnothing$  50 mm frost-free

# REMKO noise protection hood

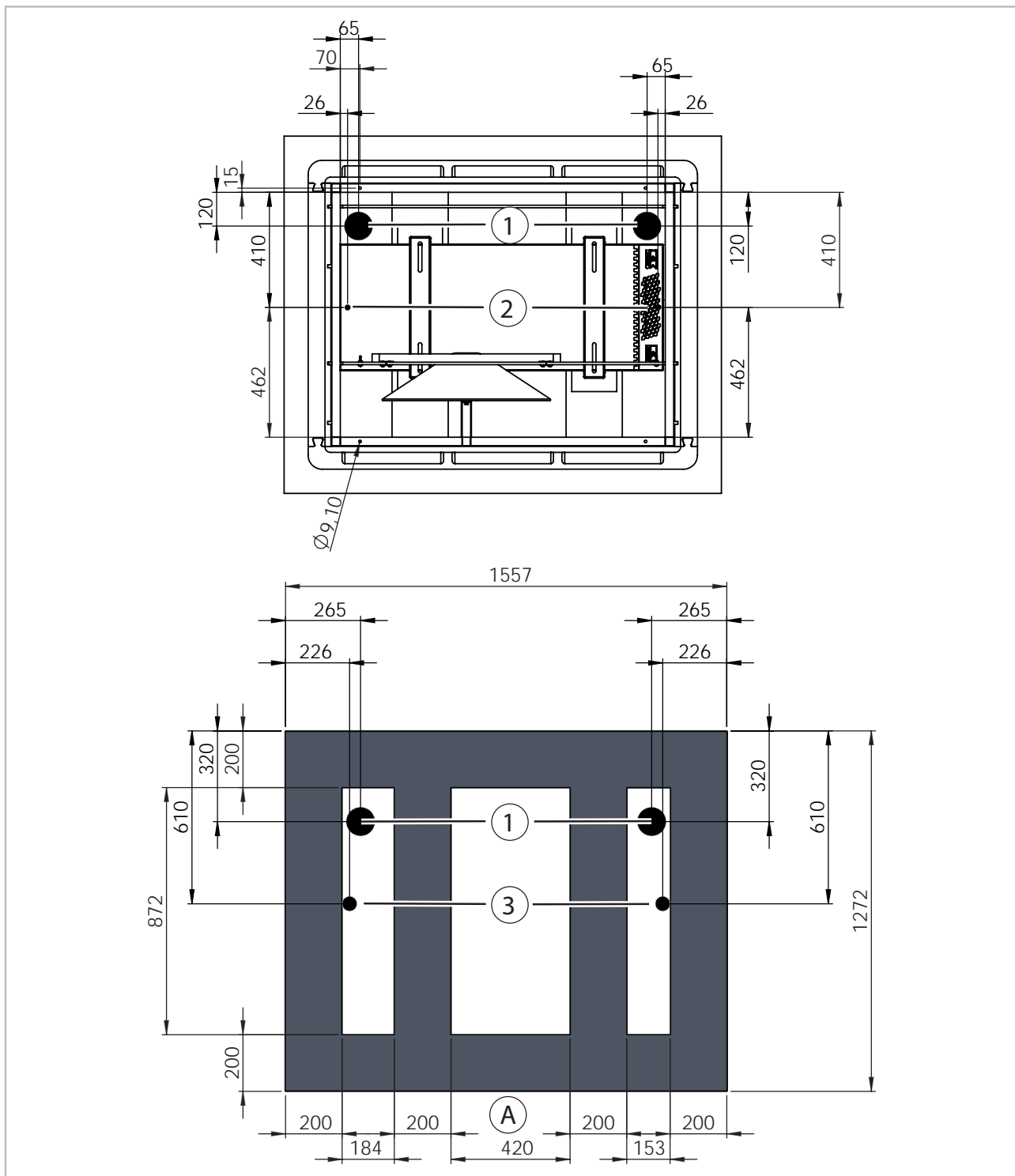

Fig. 9: Strip foundation SWK 5 and SWK 7

- A: Outdoor unit, fan side
- 1: Protection tube, optionally right or left  $\varnothing$  100 mm
- 2: Condensate drain connection, optionally right or left min.  $\varnothing$  20 mm
- 3: Condensate drain, optionally left or right min.  $\varnothing$  50 mm frost-free

## Condensate drainage connection and safe drainage

### Condensate drainage connection

If the temperature falls below the dew point, condensation will form on the finned condenser during **heating mode**.

A condensate tray should be installed on the underside of the unit to drain any condensate.

- The condensate drainage line must be provided by the customer and have an incline of at least 2 %. If necessary, fit vapour-diffusion-proof insulation.
- When operating the unit at outside temperatures below 4 °C, ensure the condensate drainage line is laid to protect it against frost. The lower part of the housing and condensate tray is also to be kept frost free in order to ensure permanent draining of the condensate. If necessary, fit a pipe heater.
- Following installation, check that the condensate run off is unobstructed and ensure that the line is durably leak tight.

### Safe drainage in the event of leakages

The REMKO oil separator OA 2.2 fulfils the following list of requirements from regional regulations and laws.

#### **! NOTICE!**

Local regulations or environmental laws, for example the German Water Resource Law (WHG), can require suitable precautions to protect against uncontrolled draining in case of leakage to provide for safe disposal of escaping refrigerator oil or hazardous media.

#### **! NOTICE!**

With the connection of an external drain line to the oil separator, it must be kept frost-free.

# REMKO noise protection hood

## 5 Design of the noise protection hood

Components on the noise protection hood

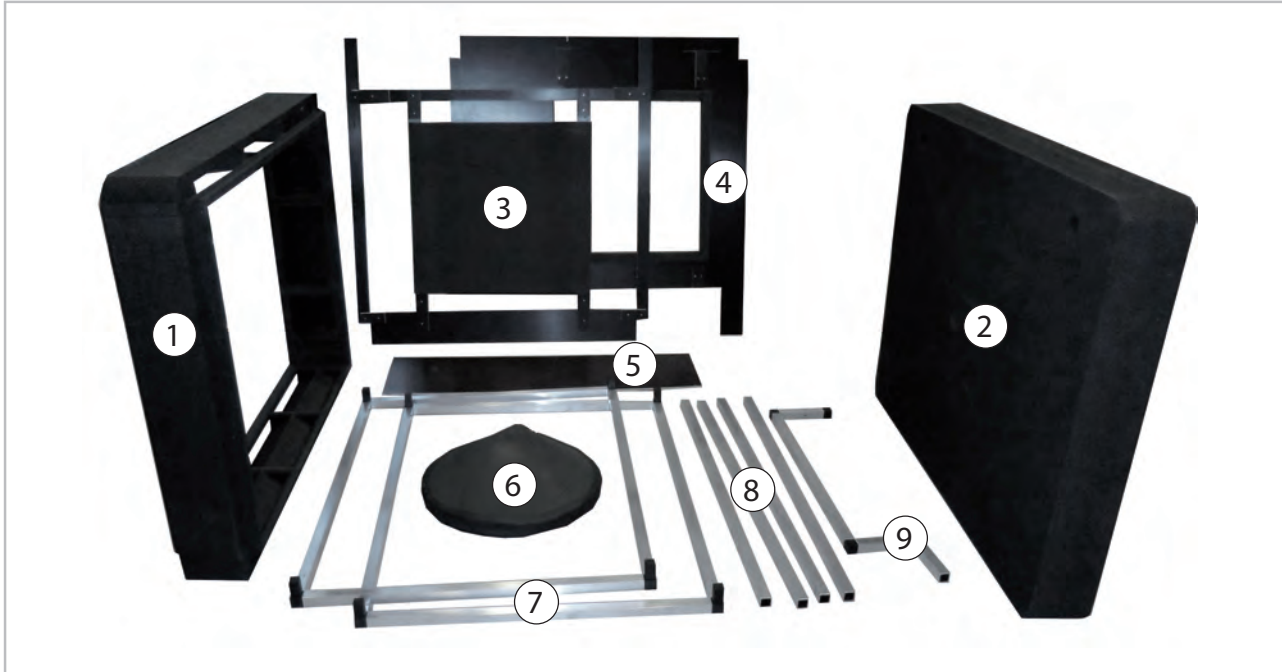

Item	Designation	Number		
		SWK 4	SWK 5	SWK 7
1	Ring element	4	5	7
2	Cover	1	1	1
3	Air intake baffle plate	1	1	1
4	Air outlet baffle plate	1	1	1
5	Base air outlet baffle plate	1	1	1
6	Buffer	1	1	2
7	Top/bottom aluminium frame	2	2	2
8	Aluminium support	4	4	4
9	Buffer support	1	1	1
<b>Components not illustrated</b>				
	Holding eyelets	2	2	2
	Strap	2	2	2
	M5 x 50 mm installation screws and washers for buffer	2	2	4
	M6 x 120 mm threaded rod for cover (top aluminium frame)	4	4	4
	M6 nuts and washers to affix the cover	4	4	4
	Cover sealing cap	4	4	4
	Corner connector	8	8	8



In order to assemble the noise protection hood, proceed as follows:

1. ➤ Install the outdoor unit with the relevant floor consoles and the condensate catch pan as described in the relevant installation manual for the heat pump/air conditioning unit. REMKO recommends using the REMKO BK 600 plus floor consoles for installation. If the noise protection hood is retrofitted to an outdoor unit that is already installed, the floor consoles such as the REMKO BK 1000 plus must be installed at right angles to the outdoor unit as described in point 3. Minimum distance to the floor = 20 cm!



Fig. 10

2. ➤ The noise protection hood must be installed on a base that is defined as suitable according to the dimensions. It can be installed on a foundation that is manufactured separately or on ground that is prepared for the installation (see the drawings in [Chapter 4 'Setting up the outdoor unit and the noise protection hood'](#) on page 19 and 11). Start with the bottom aluminium frame when installing. Ensure that the aluminium frame is connected securely to the base (e.g. using anchor bolts, ground anchors or fixed screw connections) so that the entire noise protection hood is attached securely.

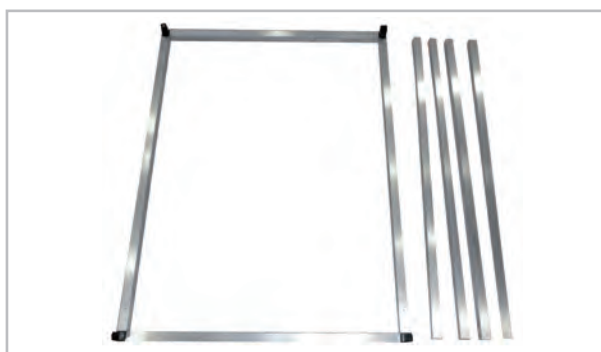

Fig. 11

3. ➤ Place the installation frame ( [↪ 'Components on the noise protection hood'](#) on page 24, item 7 ) over the heat pump's outdoor unit and arrange the frame so that it has an even gap all around the unit. Check whether the relevant holes to attach the noise protection hood enable it to be attached securely. As there are several options for this, there are no installation materials included with the SWK noise protection hood for attaching. These attachments must be provided by the customer.



Fig. 12

4. ➤ If the refrigerant piping is laid visibly from the rear for installation on the outdoor unit (Fig. 13), the frame must be installed below the piping. If the refrigerant piping is installed on the outdoor unit from the bottom and is not in the vicinity of the ring elements on the noise protection hood, you can continue installation without an opening. If this is the case, continue installation as described in point 7.



Fig. 13

# REMKO noise protection hood

5. ➤ To open the bottom frame, pull the corner connector out of the aluminium pipe and install the aluminium pipe below the refrigerant piping.



Fig. 14

6. ➤ After you have installed the aluminium pipe below the refrigerant piping, re-assemble the corner connector completely.



Fig. 15

7. ➤ Once you have installed the bottom aluminium frame, place the first ring element (☞ 'Components on the noise protection hood' on page 24, item 1) over the outdoor unit (Fig. 16 and Fig. 17) and draw the position of the refrigerant piping on the ring element accordingly so that you can remove the opening from the ring element. Lift the ring element off the outdoor unit again and remove the area that you previously drew. To remove the opening for the piping, use suitable tools such as a cutting knife, a jigsaw or a long saw blade.



Fig. 16

8. ➤ After you have created the opening, place the ring element back over the outdoor unit and secure it around the aluminium frame (Fig. 17).

Ensure that the attachment point required to attach the buffer at a later time is in the middle in front of the fan.

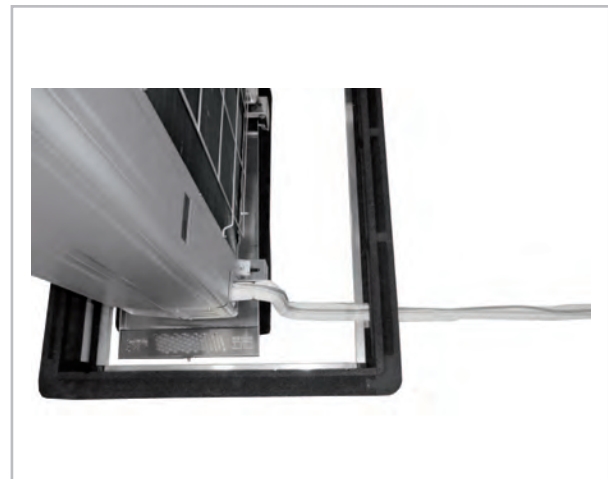

Fig. 17

9. ➤ Now place the enclosed aluminium supports at the corners of the aluminium frame (☞ 'Components on the noise protection hood' on page 24, item 8) and attach them. (Fig. 18). Only use suitable tools for this, such as a rubber hammer, in order to prevent damage to the aluminium profiles.



Fig. 18

- 10.** Ensure that all four supports are completely pushed into the corner connectors in order to guarantee that they are aligned (Fig. 19).



Fig. 19

- 11.**

**⚠ CAUTION!**

Ensure that the outdoor unit is shut down and secured to prevent a restart during the installation, maintenance and repair times in order to prevent injuries caused by the fan starting up!

Remove the grille in front of the fan (exhaust side) by removing the four screws in the corners. Both grilles must be removed on outdoor units that have two fans. The grilles are no longer required to operate the system. The second ring element (☞ 'Components on the noise protection hood' on page 24, item 1) can now be placed on the first ring element (Fig. 20).



Fig. 20

- 12.** Now take the baffle plate for the air outlet (☞ 'Components on the noise protection hood' on page 24, item 4) and slide it into the EPP ring's groove on the air outlet side.



Fig. 21

- 13.**



Use the fan grille for maintenance purposes.

Insert the air inlet baffle plate with the foam insulation side to the inside towards the outdoor unit. The baffle plate for the air inlet must rest with the supporting feet at the bottom on the aluminium frame (Fig. 22).

# REMKO noise protection hood

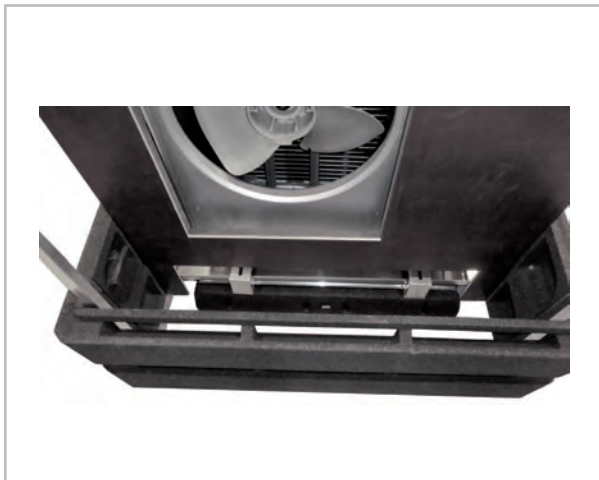

Fig. 22

- 14.** To install the baffle plate, guide it into the opening (groove) provided. When installing each additional ring element, the baffle plate for the air outlet must always be installed through the opening.

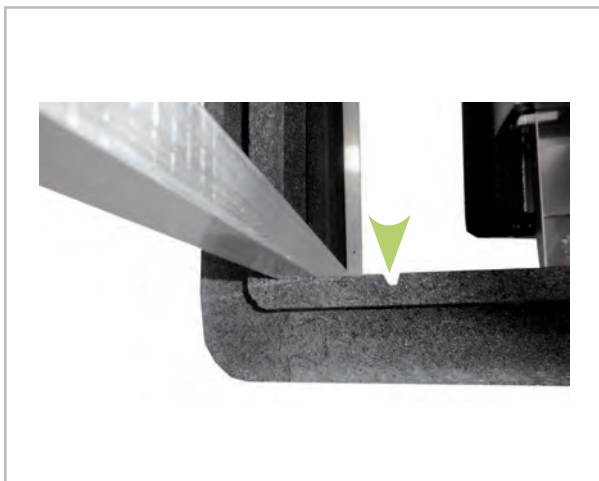

Fig. 23

- 15.** The baffle plate for the air outlet must rest with the side of the foam insulation directly on the outdoor unit.

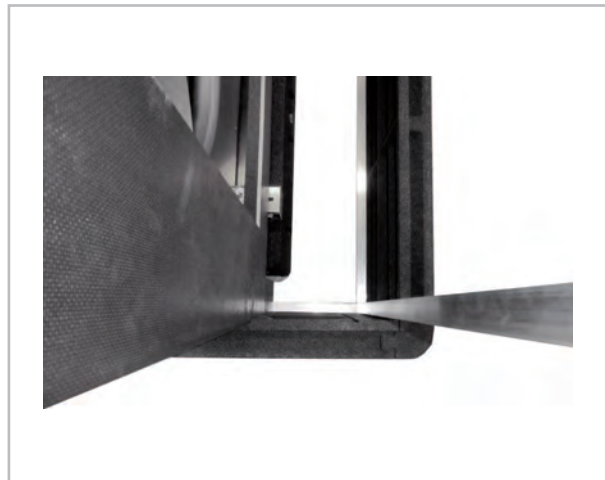

Fig. 24

- 16.** After it has been installed, as shown in Fig. 25, the baffle plate is horizontal in the noise protection hood, directly in front of and tight to the outdoor unit.

The aluminium frame must now be connected to the base using suitable attachment materials. If a concrete foundation/strip foundation or flagstones are used, you must use corresponding screws and anchor bolts. If the noise protection hood is to be installed on ground that has been prepared for it, use suitable ground anchors. If the hood is not attached, it is not secured against wind loads and operation of the entire system is not permitted. If the wind load is expected to be higher than normal, REMKO recommends securing the hood with additional storm ropes.

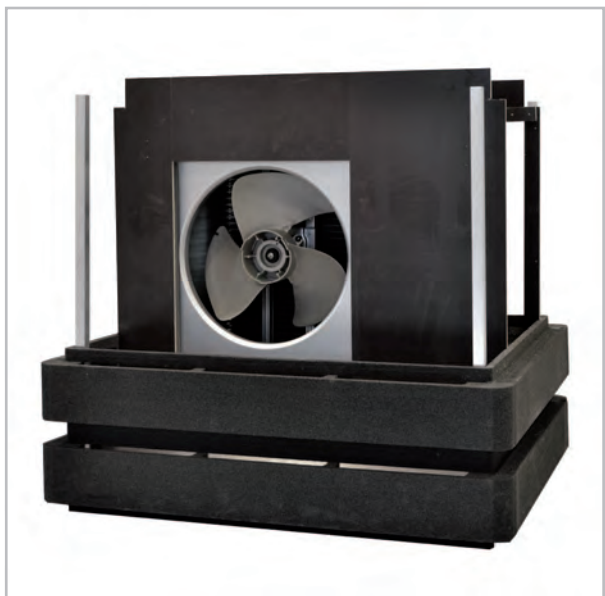

Fig. 25

- 17.** Now take the baffle plate base for the air outlet (☞ ‘Components on the noise protection hood’ on page 24, item 5) and place it at an angle at the bottom in front of the condensate tray.



Fig. 26: Installation-17

- 18.** The baffle plate on the base is to prevent an air short circuit. It is not screwed on and must be installed flush to the cover for the air outlet (Fig. 27).



Fig. 27

- 19.** Now take the baffle plate for the air inlet (☞ ‘Components on the noise protection hood’ on page 24, item 3) and install this baffle plate in the air intake at the rear of the SWK noise protection hood.



Fig. 28

- 20.** Insert the baffle plate with the foam insulation side to the inside with a gap to the outdoor unit in the first opening on the ring element. The baffle plate is not installed directly on the outdoor unit and must rest with the side supporting feet at the bottom on the aluminium frame to intake air.



Fig. 29

- 21.** Install the baffle plate for the air inlet evenly in the relevant opening (groove) until it is resting with both adjustment feet on the bottom aluminium profile. When installing the subsequent ring elements, the baffle plate for the air inlet and outlet must always be pushed into the same openings.

# REMKO noise protection hood

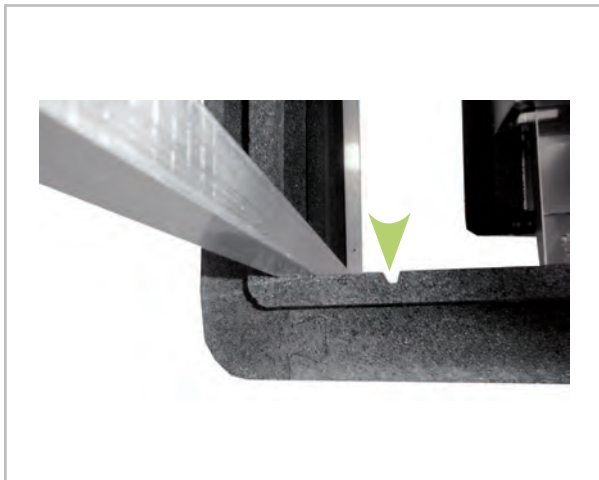

Fig. 30

**22.** The holding eyelets supplied must now be attached to the top of the air outlet baffle plate using the corresponding screws. The holding eyelets must be installed on the top of the baffle plate for the air outlet in such a way that the attachment strap is fixed through the grille on the air inlet at the height of the top fastening screw.

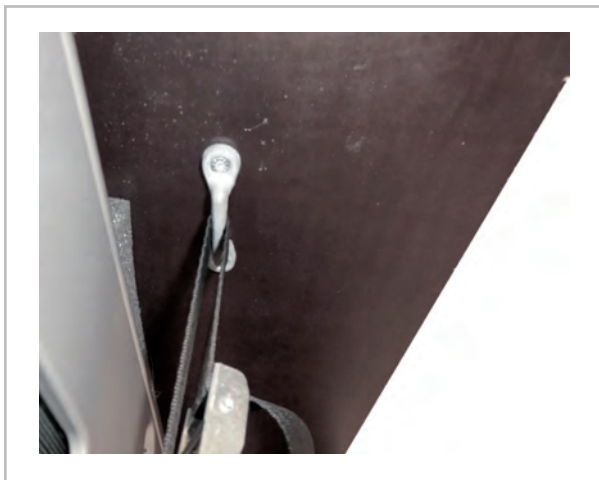

Fig. 31

**23.** After installing the holding eyelets on the left and right of the baffle plate for the air outlet, use the straps supplied to attach it so that it is flush with the housing on the outdoor unit. Ensure that the baffle plate is tight to the outdoor unit's housing. To do this, you must press the baffle plate tightly onto the housing. It is sufficient for the baffle plate to be installed tight and flush to the outdoor unit (Fig. 32).



Fig. 32

**24.** The supports to attach the buffer (☞ 'Components on the noise protection hood' on page 24 and the top aluminium frame (☞ 'Components on the noise protection hood' on page 24, item 7) and , item 9) must now be installed. Ensure that the top attachment point for the buffer's support is in the middle in front of the fan opening (Fig. 33).



Fig. 33

- 25.** The support for the buffer (Fig. 34) is installed on the fastening point on the top and bottom aluminium frame, as shown in Fig. 35.



Fig. 34

- 26.** All connections on the top and bottom frame, as well as the supports, must be connected completely. Only use suitable tools for installation in order to prevent damage to the aluminium profiles.

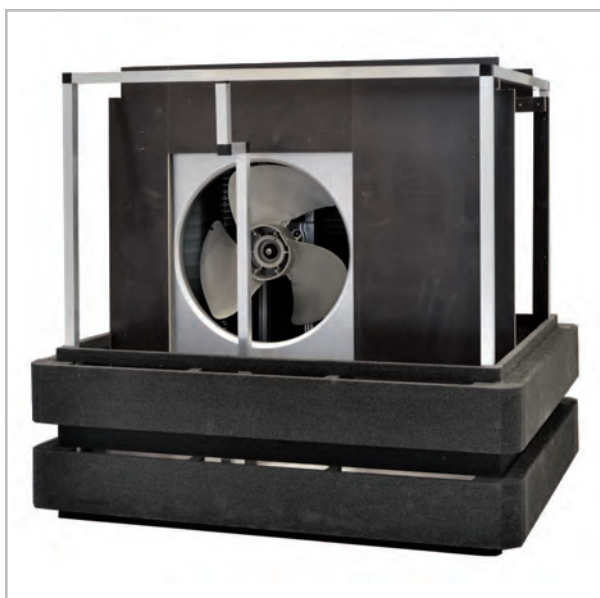

Fig. 35

- 27.** The buffer supplied (Fig. 36) can now be installed using two screws and washers (M8). Two buffers and the corresponding screws are supplied for outdoor units that have two fans.



Fig. 36

- 28.** Use the M8 x 50 mm screws supplied to install the buffer. When installing, use the openings that are provided in the supports and install the buffer as shown in Fig. 37. Both buffers must be installed directly in front of the relevant fan on outdoor units that have two fans.

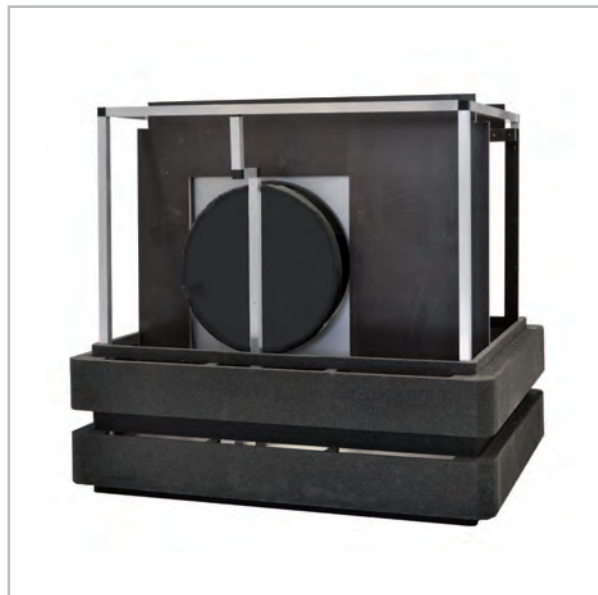

Fig. 37

# REMKO noise protection hood

**29.** ▶ To continue installation, place the next ring element on the elements that have already been installed.

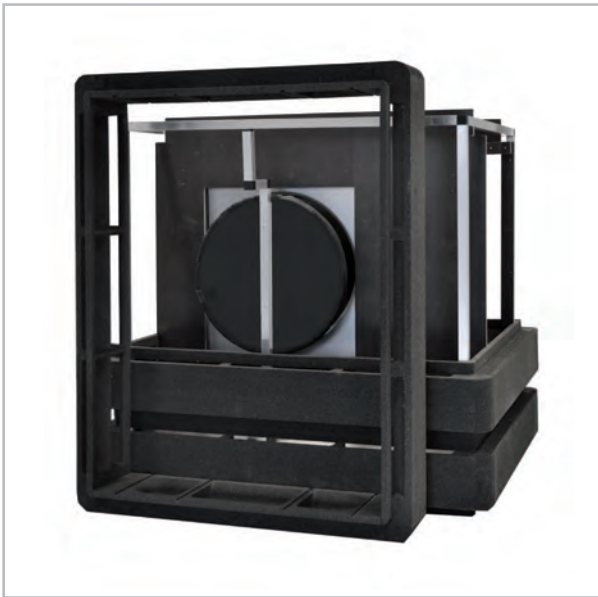

Fig. 38

**30.** ▶ The third ring element must rest completely on the element below.



Fig. 39

**31.** ▶ Always place each additional ring element completely on the bottom element until you only have the cover left. The REMKO WKF 70 heat pump includes four ring elements, the WKF 120 unit series contains five ring elements and the WKF 180 unit series contains seven ring elements.



Fig. 40

**32.** ▶ After installing the ring elements, the aluminium frame can still be seen at the top edge. To install the top cover, you must screw the four M6 x 120 mm threaded rods supplied into the corresponding M6 threaded sleeves.



Fig. 41



- 33.** To install, screw the threaded rods two centimetres into the threaded sleeve until the threaded rod protrudes 10 cm from the top edge of the aluminium profile to the top edge of the threaded rod.

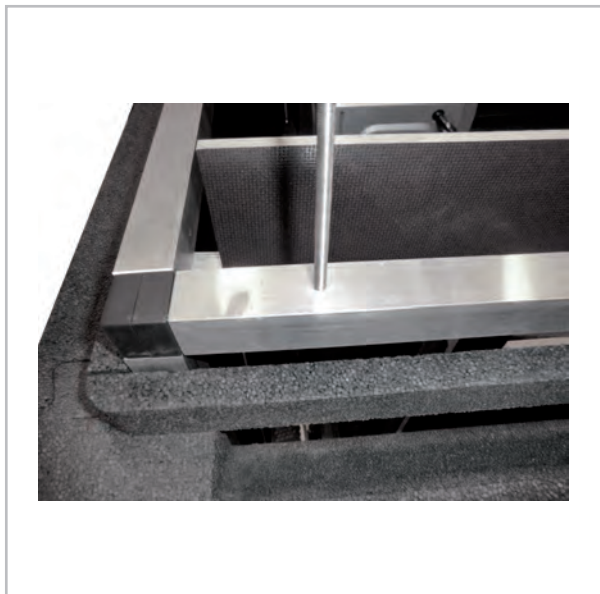

Fig. 42

- 34.** Check that all openings provided for fastening on the cover plate are open. If there are blocked openings, use suitable tools to remove any EPP residues from the openings.



Fig. 43

- 35.** The cover can now be installed on the ring elements and attached using the M6 nuts and washers provided. After fastening the lock screws, place the cover plates in the openings for the screws. Installation of the REMKO SWK noise protection hood is now complete.



Fig. 44

# REMKO noise protection hood

## Maintenance on the outdoor unit

### CAUTION!

Ensure that the outdoor unit is shut down and secured to prevent a restart during the installation, maintenance and repair times in order to prevent injuries caused by the fan starting up!

If maintenance is to be carried out on the outdoor unit, the SWK noise protection hood must be removed in reverse order. You do not have to remove all ring elements to do this. The bottom two or three ring elements can remain installed for maintenance.

In order to access the outdoor unit's service opening, proceed as follows:

1. ➤ Remove the cover plates by undoing the screws that are used to attach the cover to the aluminium frame.



Fig. 45

1: Cover plate, removed

2. ➤ You can now remove the ring elements by pushing them upwards on the aluminium frame one after the other.



Fig. 46

As mentioned above, the bottom two or three ring elements can remain installed for maintenance.

Then remove the corresponding side part of the casing and open the mounting opening on the outdoor unit of the REMKO heat pump.



Fig. 47

## 6 Exploded view of product and spare parts

### 6.1 Exploded view of and spare parts list for noise protection hood SWK 4

Exploded view of the housing

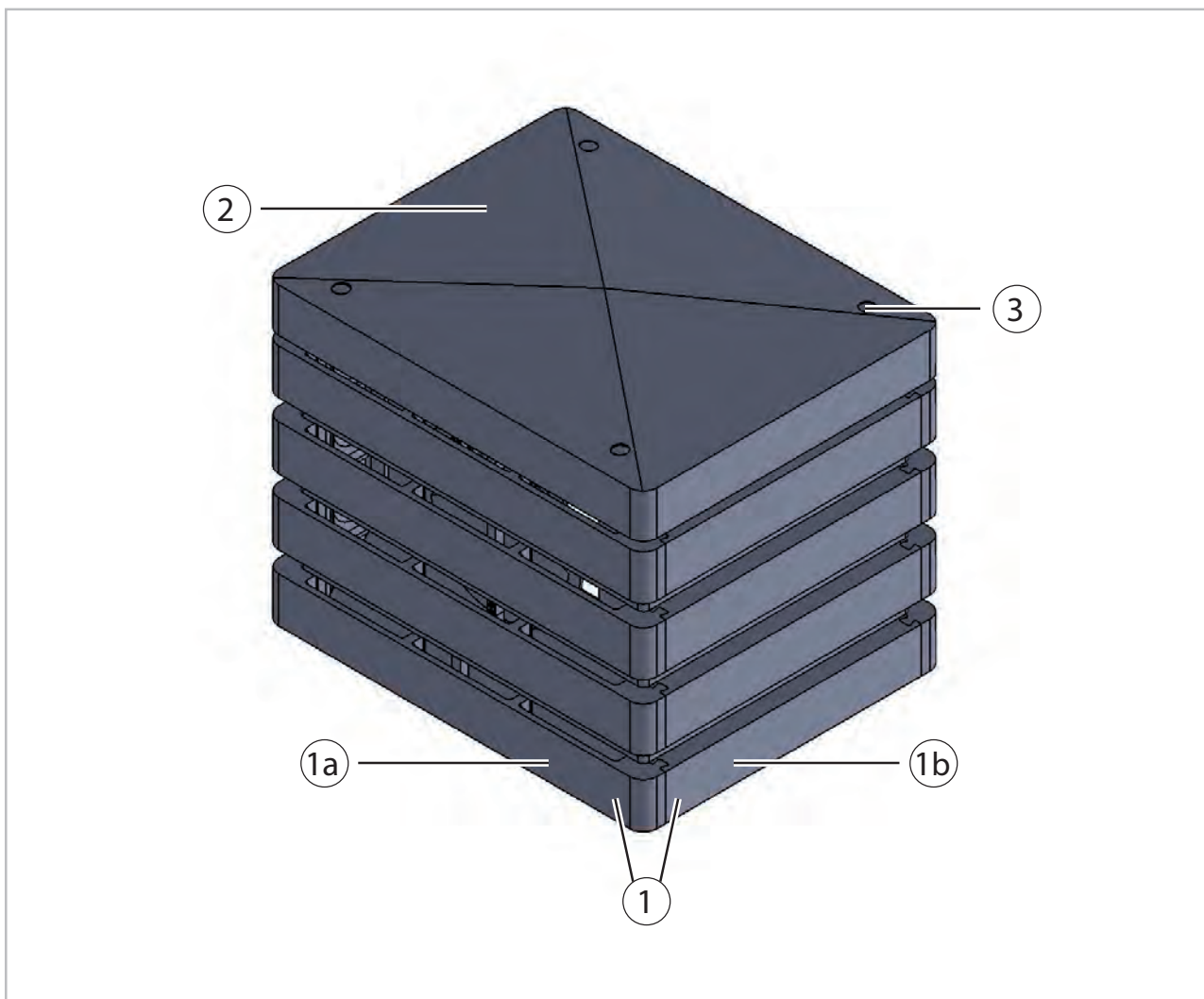

Fig. 48

No.	Spare parts	Quantity	Model	
			Black	Silver black
			EDP	EDP
1	Complete ring element comprising 2 x longitudinal and transverse elements each	4	260882	260888
1a	Ring element on the noise protection hood's longitudinal side	8	260881	260887
1b	Ring element on the noise protection hood's transverse side	8	260880	260886
2	Noise protection hood cover	1	260879	260885
3	Sealing cap	4	1102172	1102172

# REMKO noise protection hood

Exploded view of the interior

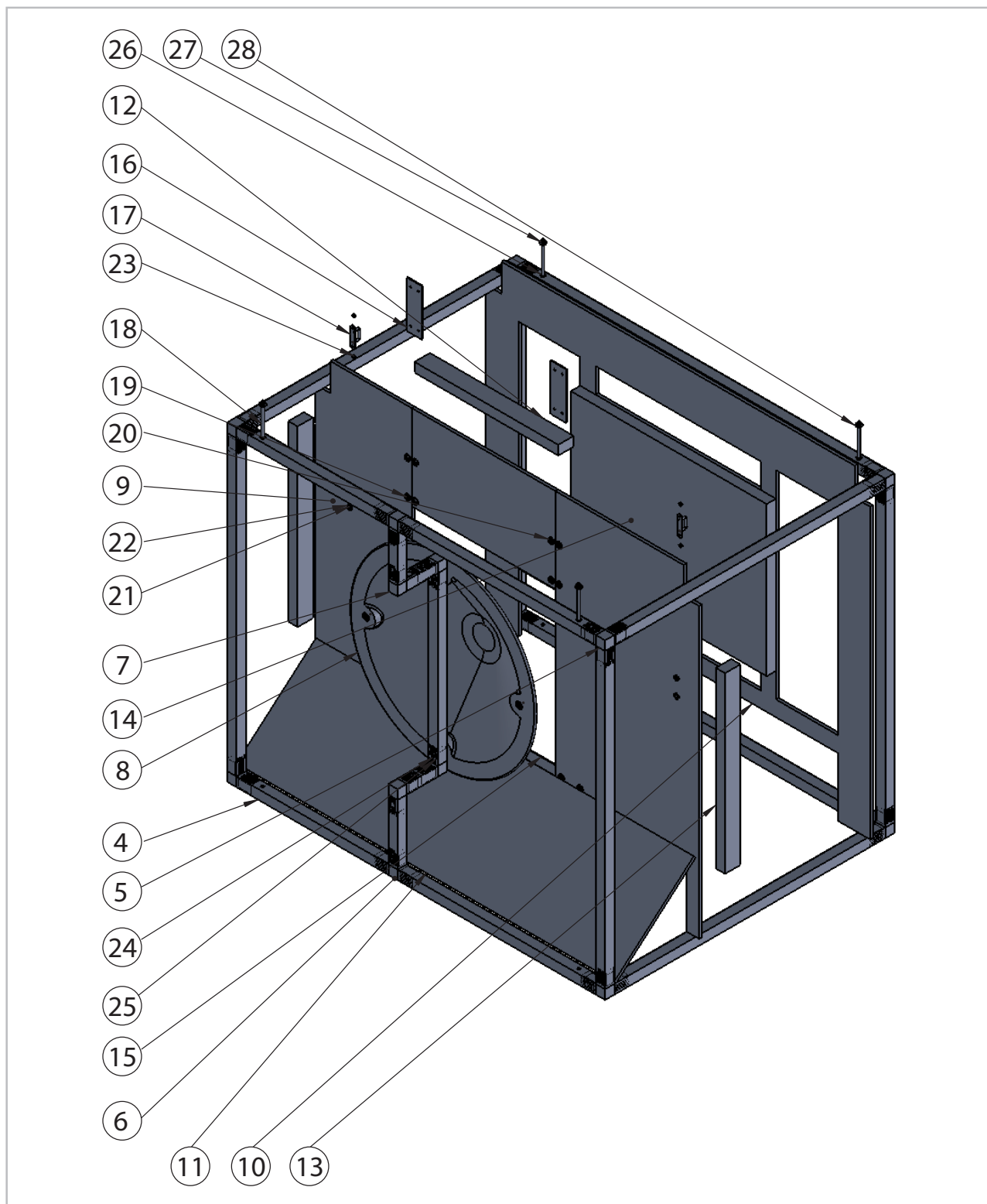

Fig. 49

### Spare parts list for the interior

No.	Spare parts	Quantity	EDP
4	Aluminium square pipes, 30 x 30 x 2.0 mm (frame)	1	1102173
5	Multi-way pipe connector, type 2 (corner connector)	8	1102174
6	Multi-way pipe connector, type 3 (T connector)	2	1102175
7	Multi-way pipe connector, type 1 (L connector)	4	1102176
8	Buffer	1	260877
9	Front screen process baffle plate	1	1102177
	Front plate neutral	1	1102210
10	Rear screen process baffle plate	1	1102178
11	Angled screen process baffle plate	1	1102179
12	Top/bottom insulation strips	2	1102180
13	Right / left insulation strips	2	1102181
14	Rear baffle plate insulation mat	1	1102182
15	3 mm aluminium bar for front baffle plate	1	1121410
16	3 mm aluminium connection plate, top, 150 x 50 mm	2	1121411
17	Belt cramp	2	1102183
18	M6 x 120 threaded pin with hexagon socket	4	1102184
19	M6 x 14 raised-head screw	12	99
20	D 6.4 washer	12	99
21	M5 x 16 raised-head screw	4	99
22	D 5.3 washer	4	99
23	M5 hexagon nut	4	99
24	M8 x 50 hexagon screw	2	99
25	D 8.4 washer	2	99
26	M6 riveting nut	4	99
27	M6 hexagon nut	4	99
28	D 6.4 washer	4	99
	Fastening belt 505 (not illustrated)	2	1000963

# REMKO noise protection hood

## 6.2 Exploded view of and spare parts list for noise protection hood SWK 5

Exploded view of the housing

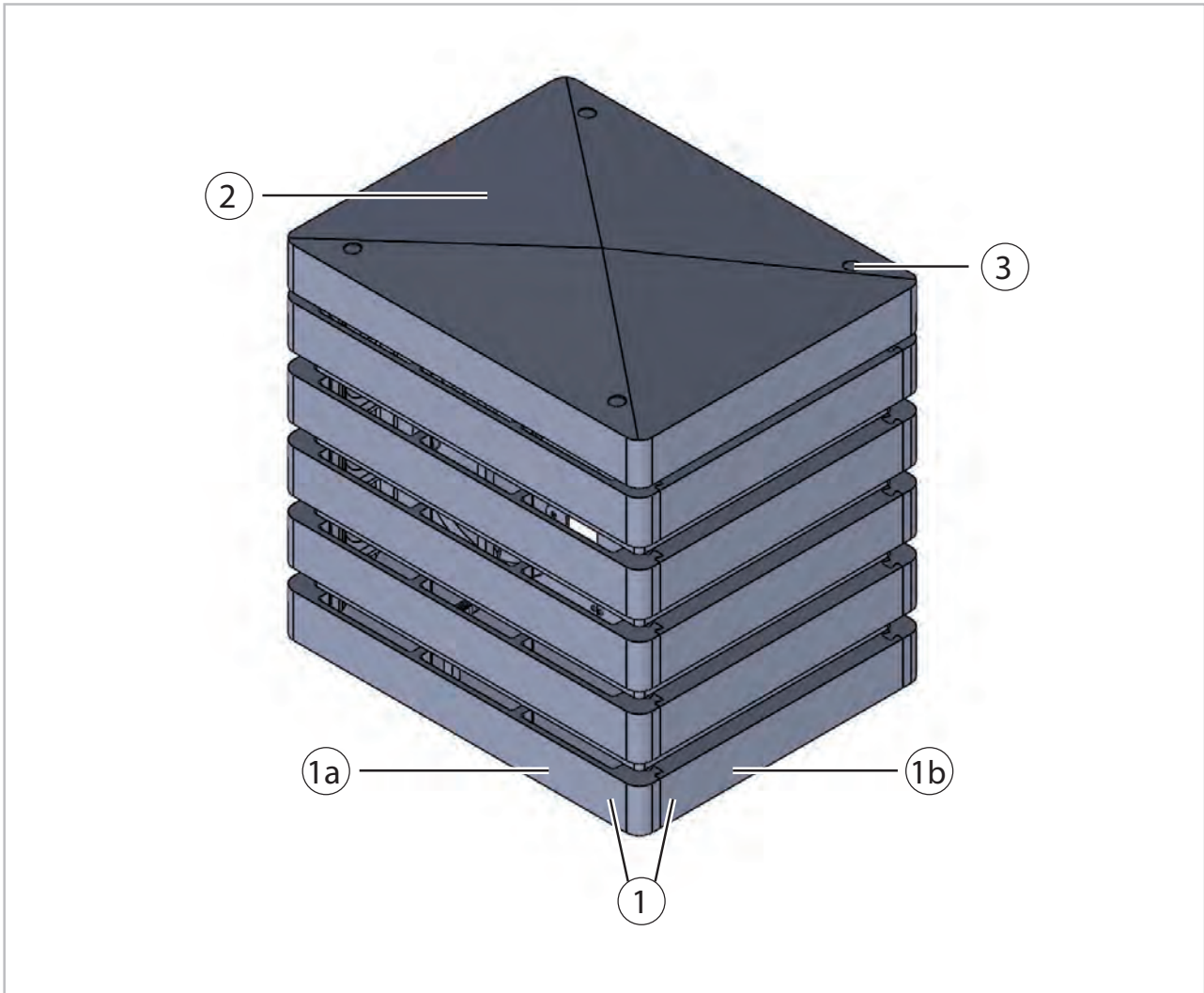

Fig. 50

No.	Spare parts	Quantity	Model	
			Black	Silver black
			EDP	EDP
1	Complete ring element comprising 2 x longitudinal and transverse elements each	5	260882	260888
1a	Ring element on the noise protection hood's longitudinal side	10	260881	260887
1b	Ring element on the noise protection hood's transverse side	10	260880	260886
2	Noise protection hood cover	1	260879	260885
3	Sealing cap	4	1102172	1102172

Exploded view of the interior

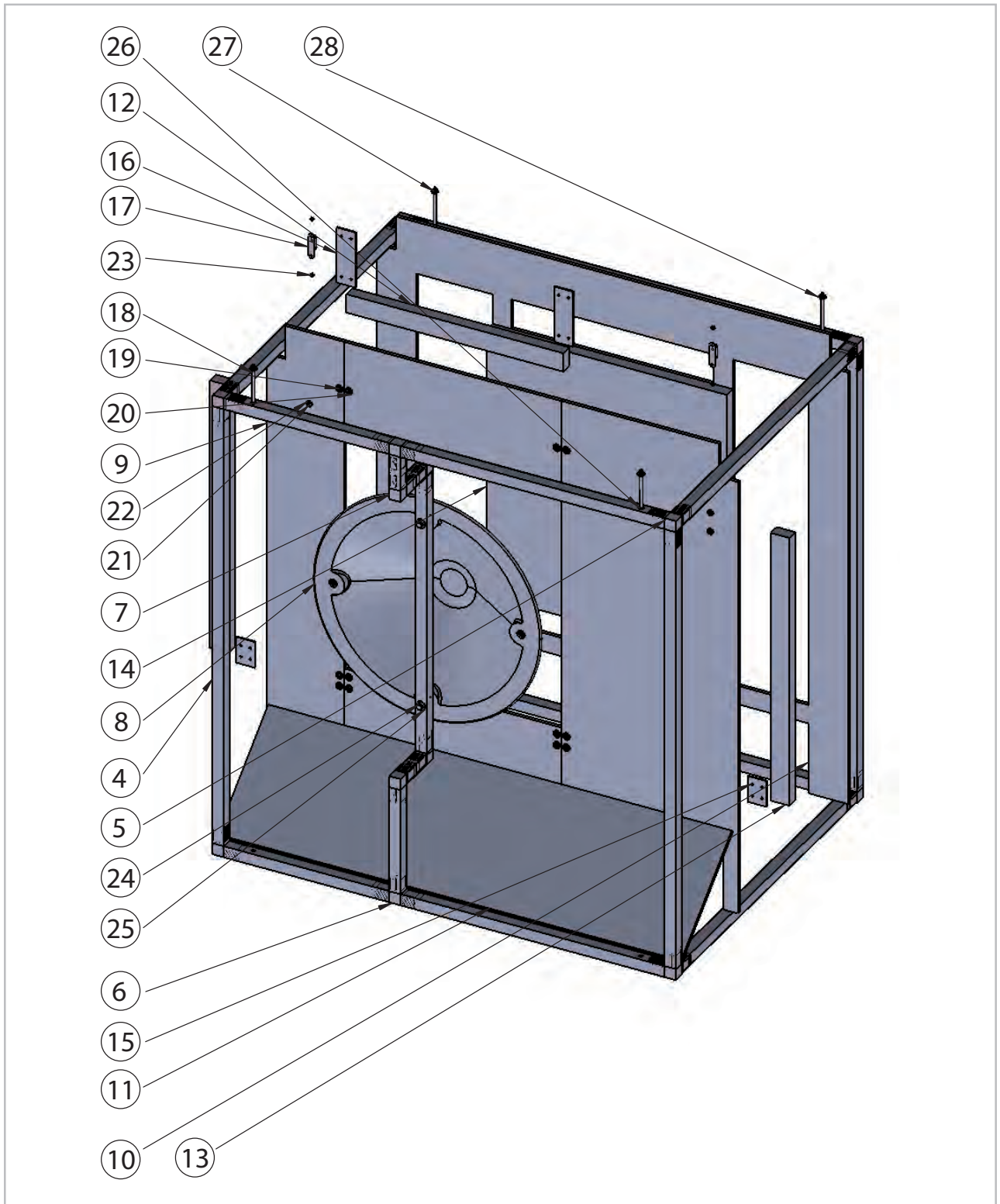

Fig. 51

# REMKO noise protection hood

## Spare parts list for the interior

No.	Spare parts	Quantity	EDP
4	Aluminium square pipes, 30 x 30 x 2.0 mm (frame)	1	1102173
5	Multi-way pipe connector, type 2 (corner connector)	8	1102174
6	Multi-way pipe connector, type 3 (T connector)	2	1102175
7	Multi-way pipe connector, type 1 (L connector)	4	1102176
8	Buffer	1	260877
9	Front screen process baffle plate	1	1102191
	Front plate neutral	1	1102211
10	Rear screen process baffle plate	1	1102192
11	Angled screen process baffle plate	1	1102193
12	Top/bottom insulation strips	2	1102188
13	Right / left insulation strips	2	1102194
14	Rear baffle plate insulation mat	1	1102195
15	3 mm aluminium connection plate, bottom	2	1121412
16	3 mm aluminium connection plate, top, 150 x 50 mm	2	1121411
17	Belt cramp	2	1102183
18	M6 x 120 threaded pin with hexagon socket	4	1102184
19	M6 x 14 raised-head screw	16	99
20	D 6.4 washer	16	99
21	M5 x 16 raised-head screw	4	99
22	D 5.3 washer	4	99
23	M5 hexagon nut	4	99
24	M8 x 50 hexagon screw	2	99
25	D 8.4 washer	2	99
26	M6 riveting nut	4	99
27	M6 hexagon nut	4	99
28	D 6.4 washer	4	99
	Fastening belt 505 (not illustrated)	2	1000963



### 6.3 Exploded view of and spare parts list for noise protection hood SWK 7

#### Exploded view of the housing

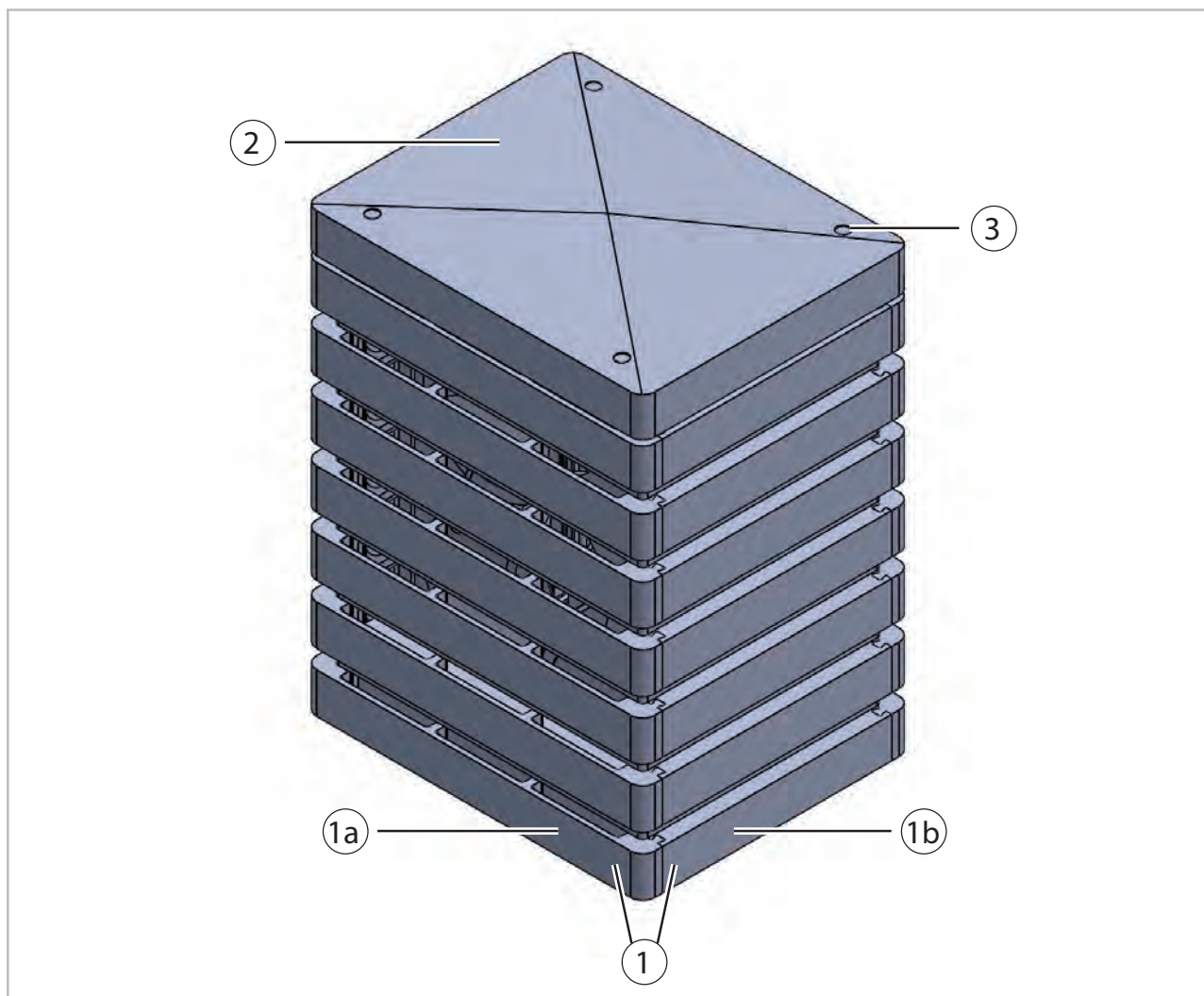

Fig. 52

No.	Spare parts	Quantity	Model	
			Black	Silver black
			EDP	EDP
1	Complete ring element comprising 2 x longitudinal and transverse elements each	7	260882	260888
1a	Ring element on the noise protection hood's longitudinal side	14	260881	260887
1b	Ring element on the noise protection hood's transverse side	14	260880	260886
2	Noise protection hood cover	1	260879	260885
3	Sealing cap	4	1102172	1102172

# REMKO noise protection hood

Exploded view of the interior

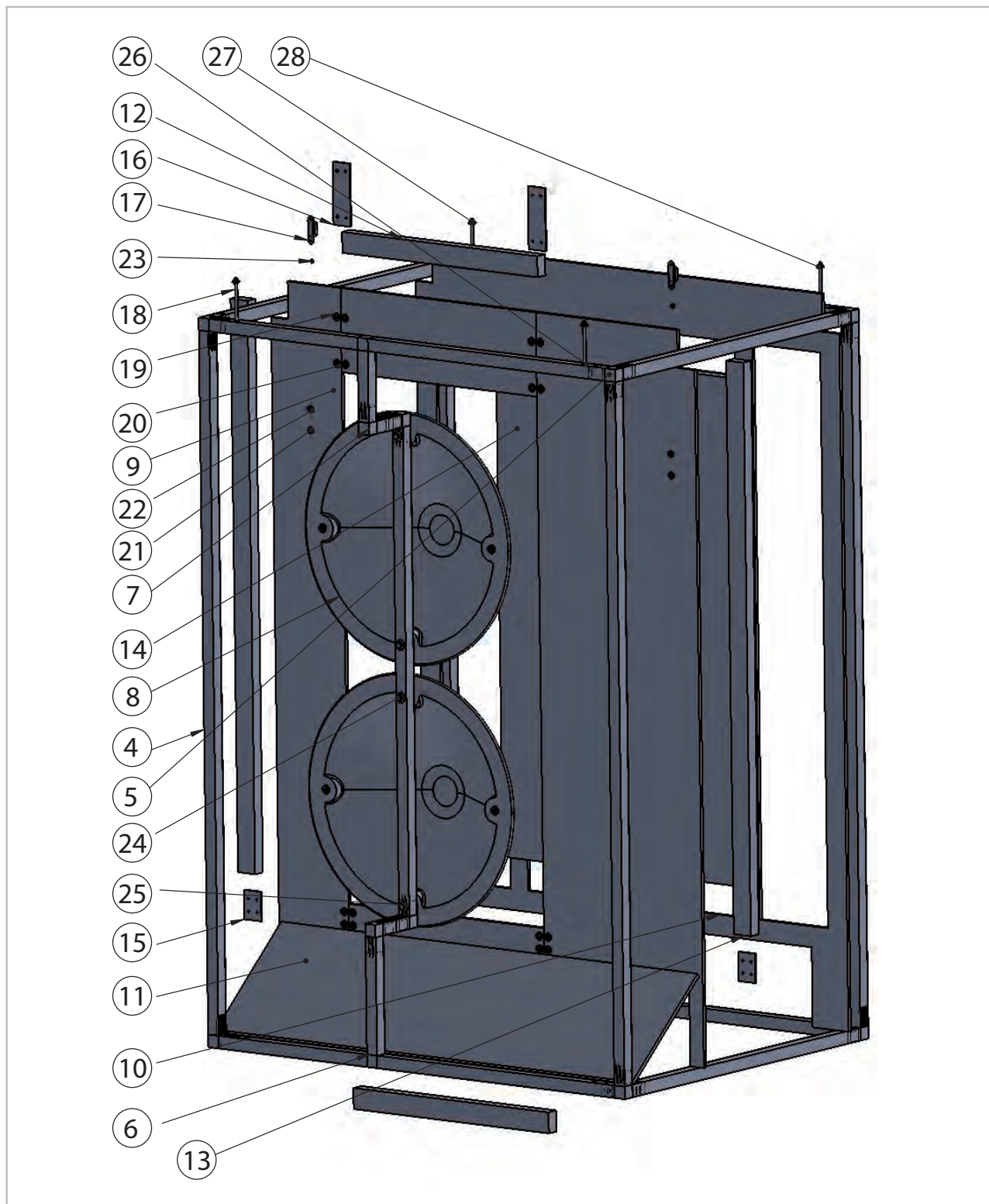

Fig. 53

### Spare parts list for the interior

No.	Spare parts	Quantity	EDP
4	Aluminium square pipes, 30 x 30 x 2.0 mm (frame)	1	1102173
5	Multi-way pipe connector, type 2 (corner connector)	8	1102174
6	Multi-way pipe connector, type 3 (T connector)	2	1102175
7	Multi-way pipe connector, type 1 (L connector)	4	1102176
8	Buffer	1	260877
9	Front screen process baffle plate	1	1102185
	Front plate neutral	1	1102212
10	Rear screen process baffle plate	1	1102186
11	Angled screen process baffle plate	1	1102187
12	Top/bottom insulation strips	2	1102188
13	Right / left insulation strips	2	1102189
14	Rear baffle plate insulation mat	1	1102190
15	3 mm aluminium connection plate, bottom	2	1121412
16	3 mm aluminium connection plate, top, 150 x 50 mm	2	1121411
17	Belt cramp	2	1102183
18	M6 x 120 threaded pin with hexagon socket	4	1102184
19	M6 x 14 raised-head screw	16	99
20	D 6.4 washer	16	99
21	M5 x 16 raised-head screw	4	99
22	D 5.3 washer	4	99
23	M5 hexagon nut	4	99
24	M8 x 50 hexagon screw	4	99
25	D 8.4 washer	4	99
26	M6 riveting nut	4	99
27	M6 hexagon nut	4	99
28	D 6.4 washer	4	99
	Fastening belt 505 (not illustrated)	2	1000963

# REMKO noise protection hood

## 7 Index

<b>A</b>			
Assembly	25		
<b>C</b>			
Condensate drainage	23		
Condensate drainage connection and safe drainage	23		
<b>D</b>			
Dimensions			
Hoods	7		
Dimensions for noise protection hoods with outdoor units	10		
<b>E</b>			
Environmental protection	6		
<b>F</b>			
Fire behaviour	11		
Fire classification	11		
Foundations	20		
<b>G</b>			
Guarantee	6		
<b>H</b>			
Hoods, dimensions	7		
<b>I</b>			
Intended use	5		
<b>M</b>			
Maintenance on the outdoor unit	34		
		Minimum distances	10
		<b>P</b>	
		Packaging, disposal	6
		<b>R</b>	
		Recycling	6
		Reduce the sound power level	12, 14, 16
		<b>S</b>	
		Safe drainage in the event of leakages	23
		Safety	
		Dangers of failure to observe the safety notes	4
		General	4
		Identification of notes	4
		Instructions for the operator	5
		Note for inspection work	5
		Note for installation work	5
		Personnel qualifications	4
		Safety-conscious working	5
		Unauthorised modification	5
		Unauthorised replacement part manufacture	5
		Service opening on the outdoor unit	34
		Sound power level	13, 15, 17
		Strip foundations	20
		<b>T</b>	
		Technical data	11
		<b>U</b>	
		Unit disposal	6



# REMKO noise protection hood



# REMKO INTERNATIONAL

*... and also right in your neighbourhood!  
Make use of our experience and advice*



**REMKO GmbH & Co. KG**  
Air conditioning and heating technology

Im Seelenkamp 12      D-32791 Lage  
Postfach 1827        D-32777 Lage  
Telephone            +49 5232 606-0  
Telefax                +49 5232 606-260  
E-mail                 info@remko.de  
Website                www.remko.de

## **Consulting**

Thanks to intensive training, our consultants are always completely up-to-date in terms of technical knowledge. This has given us the reputation of being more than just an excellent, reliable supplier:

REMKO, a partner helping you find solutions to your problems.

## **Distribution**

REMKO offers not just a well established sales network both nationally and internationally, but also has exceptionally highly-qualified sales specialists.

REMKO field staff are more than just sales representatives: above all, they must act as advisers to our customers in air conditioning and heating technology.

## **SFlbCustomer Service**

Our equipment operates precisely and reliably. However, in the event of a fault, REMKO customer service is quickly at the scene. Our comprehensive network of experienced dealers always guarantees quick and reliable service.

